

QUICK SETUP

Series SLA



WARNING: Ensure that you are wearing proper PPE before performing any action.

This document applies to vertical and horizontal motor orientations.

Tool Requirements

- Open-End Wrenches: Sizes required will depend on motor frame
- Packing Gland Tool: T10010

Pump Mounting

1. Unpack Series SLA pump assembly, and ensure all ordered components are supplied. Fastener hardware not included. Motor sold separately.

QTY	DESCRIPTION
1	SERIES SLA PUMP
1	SHAFT COUPLING HUB + SPIDER

2. Place pump onto level mounting surface. The head should always be horizontal relative to ground with the discharge check valve vertical facing up. See Figure 1.
3. Secure pump to stable structure to avoid tipping, using four (4) holes on outer edge of standard foot mount. See Figure 2.

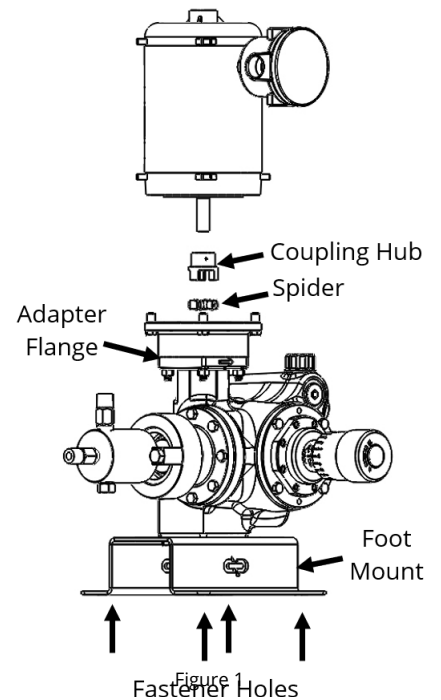

Motor Attachment

4. The Series SLA drive is designed to support up to an 85lbf (378N) motor.
5. Install coupling hub with key to motor shaft and tighten the set screw.
6. Align the motor side coupling with the factory Series SLA coupling hub, with the elastomer spider inserted.
7. Align the motor flange with the Series SLA adapter flange and secure by installing four (4) bolts (not included) sized according to the motor frame.
8. Connect motor to electrical service with overcurrent protection and means to safely interrupt power, following local rules and regulations.

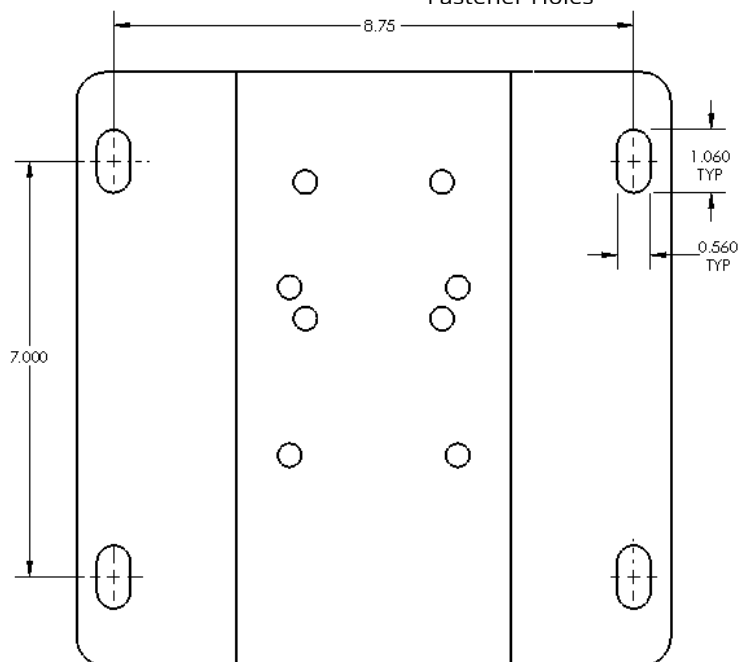

Figure 2

QUICK SETUP

Series SLA



Pump Attachment

9. Connect the suction line to the suction check valve. Connect the discharge line to the discharge check valve. Line size must be equal or greater than check valve connection. See Figure 3. Liquid level should be equal to or higher than pump inlet.
10. Note that this pump head features a non-adjustable plunger seal. The gland nut should be fully tightened. See Figure 4.
11. Always use an external pressure relief valve on the discharge side of the pump to protect from overpressure.
12. Fill gear casing with approximately 2.1qt (2.0L) oil to halfway mark on upper sight glass. See Figure 5. Use MOBIL SCH 634 Synthetic Bearing and Gear Oil.

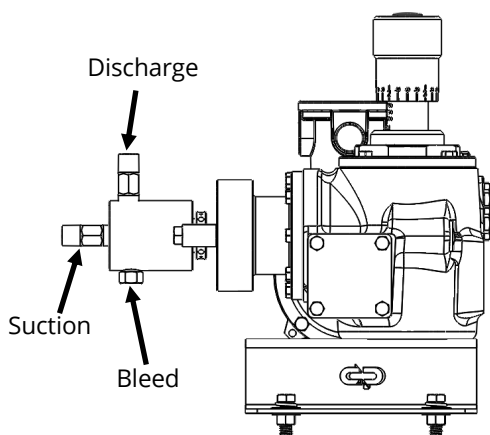

Figure 3

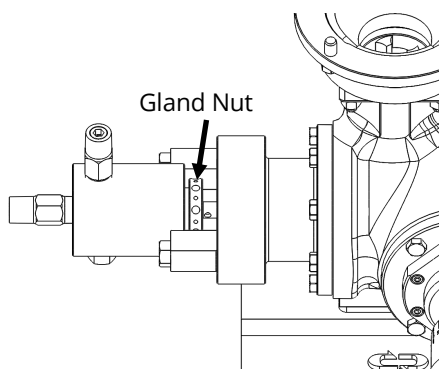

Figure 4

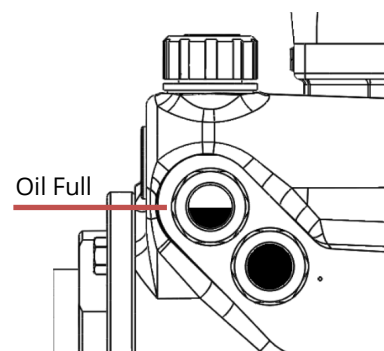

Figure 5

WARNING: Pump surfaces can become hot during operation. Wear protective gloves.



CAUTION: Do not force handle during adjustment. Do not force below 0% or above 100% marks.

Chemical Flow Rate Adjustment

13. Turn the adjustment knob to increase or decrease the flow rate to the desired percentage, as indicated by the markings. See Figure 6.
14. With fluid media present at the pump suction, loosen the bleed screw and discharge line at the discharge check outlet to vent to atmosphere. Run the pump until all air trapped in the head is released. Re-tighten the discharge line and bleed screw.
15. Run a drawdown flow calibration. If the flow rate is correct, stop here. If the flow rate is incorrect, continue.
16. Turn the adjustment knob to increase or decrease the flow rate as required, then repeat Step 15.

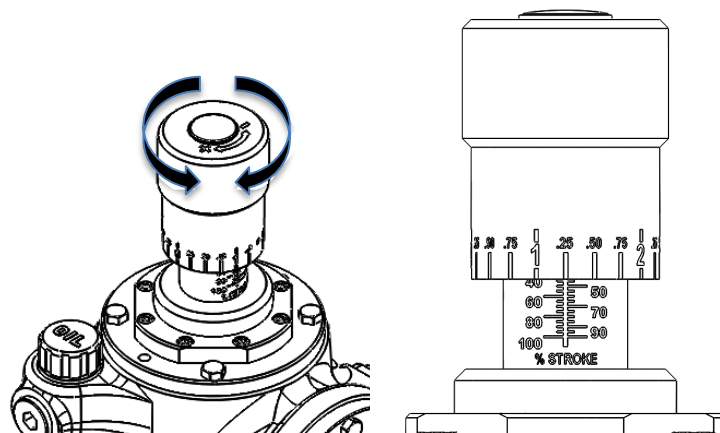

Figure 6