

Series S Solenoid Chemical Metering Pump Operating Manual



CheckPoint Headquarters
21356 Marion Lane
Mandeville, Louisiana 70471
United States of America
+1 (504) 340-0770

CheckPoint UK
C2/C3 Lombard Centre
Kirkhill Place, Kirkhill Industrial
Dyce, Aberdeen AB21 0GU
+44 (0)1224 775205

CP Pumps & Systems FZE
Unit AA08, LIU 10
Jebel Ali South | PO Box 262131
Dubai | UAE
+971 (4) 8806278

TABLE OF CONTENTS

1. INTRODUCTION	1
1.1 Scope.....	1
1.2 Model Numbering	2
2. UNPACKING	3
2.1 Damage.....	3
2.2 Contents.....	3
3. SAFETY CONSIDERATIONS	3
3.1 Chemical Compatibility	3
3.2 Safety and Preparation.....	4
4. INSTALLATION	4
4.1 Location	4
4.2 Electrical.....	4
4.3 Plumbing	4
5. START-UP	7
5.1 Priming the Pump.....	7
5.2 Adjusting the Feed Rate.....	7
5.3 Stroke Length.....	7
5.4 Calculating Output	7
5.5 Optimal Features.....	8
6. MAINTENANCE	8
6.1 Diaphragm Replacement.....	9

6.2	Suction and Discharge Check Valve Replacement.....	9
6.3	PVDF Liquid End Diagram.....	10
6.4	SS316 Liquid End Diagram.....	11
6.5	Replacement Parts.....	12
7.	<i>TROUBLESHOOTING</i>	14
8.	<i>APPLICATION NOTES</i>	16

Congratulations! You have chosen the finest, most versatile, chemical injection pump made; designed to superior specifications for long life, reliable performance, and low maintenance. To maximize the Series S's durability and to ensure proper operation, please read and follow this manual. Failure to correctly install and maintain the pump is the primary cause of premature pump failure and voids the product warranty.

NOTE: This IOM applies to the CheckPoint **Series S** Chemical Injection Pump.

NOTE: Important illustrations, graphs, and charts are located throughout this manual.

Manufacturer's Product Warranty

CheckPoint warrants this product to be free of defects in material or workmanship. Liability under this policy extends for 24 months from date of purchase. Liability is limited to repair or replacement of any failed equipment or part proven defective in material or workmanship upon manufacturer's examination. Removal, installation, and shipping costs are not included under this warranty. Manufacturer's liability shall never exceed the selling price of equipment or part in question. CheckPoint disclaims all liability for damage caused by its products by improper installation, maintenance, use or attempts to operate products beyond their intended functionality, intentionally or otherwise, or any unauthorized repair. CheckPoint is not responsible for damages, injuries or expense incurred through the use of its products.

The above warranty is in lieu of other warranties, either expressed or implied. No agent of ours is authorized to provide any warranty other than the above.

Warranty Process

If your unit malfunctions, call 1-800-847-7867, and provide our technician with Model and Serial Number information. If we are unable to diagnose and solve your problem over the phone, a warranty claim may be submitted. CheckPoint will provide an RMA and the problem unit must be returned for warranty inspection, to be completed within 3 weeks of receipt at the CheckPoint designated location. If the inspection results in approval of the warranty claim, a replacement unit will be sent to you at no charge.

If a replacement pump is needed immediately, you may purchase a new pump at the time the warranty claim is submitted. In that case, if the warranty process results in an approved claim, your account will be credited for the new pump purchase.

Any warranty covers only the pump. Liquid end components and other external accessories are not covered.

1. INTRODUCTION

1.1 Scope

This manual covers all facets of operation of CheckPoint's Series S pump, including unpacking, mounting, electrical and plumbing connection, and start-up. Safety, maintenance and repair, warranty, and factory information is also provided. Please read this manual completely before proceeding. Observe safety protocols and heed all warnings and precautions.

1.2 Model Numbering

The Series S pump model numbers define the output, pressure and control functions present on a particular pump. Your pump may be supplied with one or more of the options described in this manual. To determine which features may apply to your pump, check the model number label located on the pump, and reference the part number system.

Model Number

1	2	3	4	5	6	7	8	9	10	11	12	

Part Number System

Position	Code	Pump Series
1-2	S1	Series S1 Electronic Solenoid Pump

Position	Code	Flow Rate / Discharge Pressure / Diaphragm Diameter
3-6	X041	0.42 GPH (1.58 LPH) / 140 PSI (9.6 BAR) / 0.5" Diaphragm *DC Power Unit Only
	X061	0.63 GPH (2.37 LPH) / 150 PSI (10.3 BAR) / 0.5" Diaphragm
	X072	0.71 GPH (2.68 LPH) / 250 PSI (17.2 BAR) / 0.5" Diaphragm
	X121	1.25 GPH (4.73 LPH) / 110 PSI (7.5 BAR) / 0.9" Diaphragm *PVDF Head Only

Position	Code	Head & Check Body Material
7	P	PVDF Head & Checks, 1/4" MNPT, with Bleed
	S	SS316 Head & Checks, 1/4" MNPT, no Bleed

Position	Code	Check Valve Type
8	C	Ball, Ceramic
	S	Ball, SS316

Position	Code	Check Valve Seal Material
9	T	Teflon (PTFE)

Position	Code	Power Connection
10-11	A1	120VAC, USA Plug, 5.5'
	A2	240VAC, USA Plug
	D1	12VDC (Reduces Output to 10 GPD at 140 PSI & Changes Fuse to On/Off Switch)

Position	Code	Special
12	0	None

Available Models

Series S Model	Flow Rate		Discharge Pressure		Head Material	Check	Seal Material	Power
	[GPH]	[LPH]	[PSI]	[BAR]				
S1X041PCTD10	0.42	1.59	140	9.65	PVDF	Ceramic Ball	Teflon	12VDC
S1X041SSTD10	0.42	1.59	140	9.65	SS316	SS316 Ball	Teflon	12VDC
S1X061PCTA10	0.63	2.38	150	10.34	PVDF	Ceramic Ball	Teflon	120VAC 50/60 Hz USA Plug
S1X061PCTA20	0.63	2.38	150	10.34	PVDF	Ceramic Ball	Teflon	240VAC 50/60 Hz USA Plug
S1X061SSTA10	0.63	2.38	150	10.34	SS316	SS316 Ball	Teflon	120VAC 50/60 Hz USA Plug
S1X061SSTA20	0.63	2.38	150	10.34	SS316	SS316 Ball	Teflon	240VAC 50/60 Hz USA Plug
S1X072PCTA10	0.71	2.69	250	17.24	PVDF	Ceramic Ball	Teflon	120VAC 50/60 Hz USA Plug
S1X072PCTA20	0.71	2.69	250	17.24	PVDF	Ceramic Ball	Teflon	240VAC 50/60 Hz USA Plug
S1X072SSTA10	0.71	2.69	250	17.24	SS316	SS316 Ball	Teflon	120VAC 50/60 Hz USA Plug
S1X072SSTA20	0.71	2.69	250	17.24	SS316	SS316 Ball	Teflon	240VAC 50/60 Hz USA Plug
S1X121PCTA10	1.25	4.73	110	7.58	PVDF	Ceramic Ball	Teflon	120VAC 50/60 Hz USA Plug
S1X121PCTA20	1.25	4.73	110	7.58	PVDF	Ceramic Ball	Teflon	240VAC 50/60 Hz USA Plug

NOTE: Not all combinations are available. This list represents our most popular options. **If you have an option not covered, contact the factory or your dealer for more details.**

2. UNPACKING

2.1 Damage

If the shipping carton shows any signs of damage, notify the shipping company immediately upon receipt. CheckPoint cannot be held responsible for damage from shipping.

2.2 Contents

Unpack the carton, and ensure the following items are present:

1. Metering Pump
2. Operating Manual

3. SAFETY CONSIDERATIONS

NOTE: All Series S pumps are primed with water before leaving the factory. If the solution to be pumped is not compatible with water, disassemble the pump fluid end before use. After disassembly, thoroughly dry the pump head, valves, and seals before pump is reassembled and used.

3.1 Chemical Compatibility

Series S metering pumps are designed to work with most liquid chemicals depending upon your pump's liquid end materials of construction. CheckPoint offers wetted materials to the best of its ability based on experience and data available at the time of request. However, chemical compatibility of selected wetted materials is ultimately the responsibility of the customer. We recommend you consult the chemical product data sheet or contact your chemical provider to confirm compatibility with the available materials prior to purchase.

3.2 Safety and Preparation

Always wear the proper protective clothing and gear when working around chemicals and chemical metering pumps. Safety glasses, gloves, and aprons are critical in preventing accidental exposure to dangerous chemicals. Liquids under pressure can present a special hazard when a line or seal is punctured resulting in the spraying of chemical many yards away. If a chemical spillage occurs, consult the Material Safety Data Sheet (MSDS) for specific instructions regarding the chemical being used.

4. INSTALLATION

4.1 Location

Select a mounting location convenient to the chemical supply as well as a source of power for the pump. Do not install the pump in a location where the ambient temperature exceeds 120°F (50°C). Higher temperatures will affect the output as well as the useful life of the pump. While the Series S pump is suitable for most outdoor installations, do not use the standard poly tubing in direct sunlight. If you must mount pump in direct sunlight or under bright fluorescent lights use ultra-violet resistant tubing, consult your distributor or the factory. Accessory item S-00225 (plastic mounting bracket) is recommend for a secure installation.

4.2 Electrical

120V 50/60 Hz Standard: Has a voltage regulated internal power supply capable of operating in the range of approximately 95 to 135 VAC. Use a supply voltage of 100 to 120 VAC for best results. The 3-wire grounded plug must be used in a 3-wire wall plug.



240V 50/60 Hz Option: Has a voltage regulated internal power supply capable of operating in the range of approximately 195 to 260 VAC. Use a supply voltage of 210 to 250 VAC for best results.



CAUTION: NEVER REMOVE GROUND WIRE FROM PLUG!

4.3 Plumbing

4.3.1 NPT Connections

Series S pumps come standard with ¼" MNPT suction and discharge check valve connections on both the PVDF and SS316 material heads. A minimum tubing size of 3/8" is recommended. Do not reduce tubing below ¼". Use appropriately rated tubing and fittings for the installation.

4.3.2 Tubing Connections

The standard NPT connections can be adapted to flexible tubing connectors for additional installation options. If used, please adhere to the following guidelines in addition to best practices.

The Series S pump uses carefully matched components to achieve a predictable metering output. This predictability can only be maintained if all fitting sizes remain unaltered. Do not attempt to reduce tubing size below ¼". All tubing connections should be double checked to insure against leakage. If hazardous chemicals are being pumped, use shielding around discharge tubing.

Do not overtighten the tubing connectors. Tighten the fittings no more than 1/4 turn after the fitting contacts the seal. Hand tighten only. Do not use a wrench or pliers as they may damage the fittings. Do not use Teflon tape except on NPT fittings. Be sure to observe applicable local plumbing codes.

NOTE: Clear flexible tubing is not intended for pressurized use.

NOTE: When cutting lengths of tubing for your installation, ensure a clean, square cut. Use short lengths of tubing and as few connections as possible.

NOTE: There is an approximate 2.5 PSI capability lost for every 1 foot of vertical rise of the discharge tubing to the injection point.

WARNING: CLEAR FLEXIBLE TUBING IS NOT INTENDED FOR PRESSURIZED USE.

4.3.3 Tubing Connections Diagram

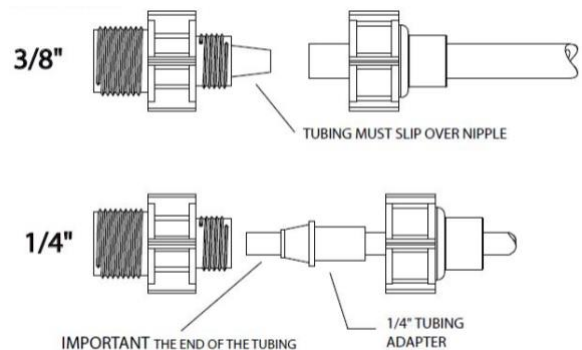

4.3.4 Suction Lift vs. Flooded Suction Installations

Suction Lift Installation

Mount the Series S pump around the top of the solution tank, not to exceed 5 feet from pump to bottom of tank.

Flooded Suction Installation

This installation is recommended for very low outputs, solutions that gasify and/or high viscosity solutions. Priming is easier and loss of prime is reduced. Failure of the pump diaphragm or rupture of the solution tubing can cause loss of solution in the tank.

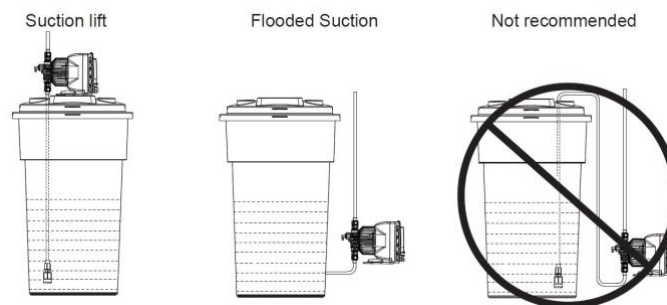

4.3.5 Wall Mounting

The fluid end portion (head assembly) of the pump is set up to accommodate mounting of the pump to the chemical container, either as a flooded suction, or a suction lift.

The pump head must be kept in a vertical position for proper operation. The head can be removed and rotated 90° if needed to keep the inlet and outlet valves in a vertical position.

4.3.6 Foot Valve Installation (Optional)

A weight is recommended to hold the tubing and foot valve in a vertical position at the bottom of the tank, especially for suction lift installations. Do not allow the foot valve to lay horizontally in the chemical container. This defeats the action of the valve and causes the pump to lose prime. Keep suction tubing reasonably short and avoid high spots or bends.

4.3.7 Injection Valve Installation (Optional)

The injection valve is designed to prevent a back flow and to inject chemical into the line. To work properly, this valve must be mounted within 45 degrees of vertical (see drawing). One end of the injection valve is 1/2" MNPT. Install this end into the piping system. Use Teflon tape on this fitting only. Connect the pump's discharge tubing to the opposite end of the injector. Do not use Teflon tape or joint compound on this fitting. Connect tubing between this fitting and the pump discharge fitting at the pump head.

NOTE: When installing into a line with zero pressure or when pumping into an open vessel, use the optional three function injection valve which provides back pressure and anti-syphon capabilities.

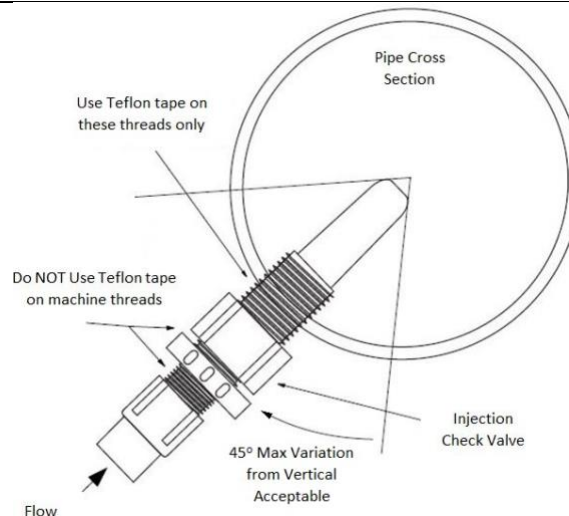

4.3.8 Optional Three Function Valve

The optional 3-function valve injection assembly provides three functions in one injection valve assembly. The anti-siphon feature allows metering of liquids "downhill" or into the suction side of a circulating pump. It provides protection against an accidental application of suction pressure at the fluid injection point. Its Teflon coated diaphragm provides a positive anti-siphon action. The back-pressure function permits metering into atmospheric discharge (open container) without over-pumping. The line check permits removal of discharge tubing without release of system fluid.

4.3.9 Priming / Degassing Valve Connection

Connect the clear poly tubing to the outlet of the bleed or priming valve. Position the free end of this tube in the chemical container. Standard PVDF head configurations include a priming valve built into the head. Clear poly tubing should be connected to the outlet of this valve; the other end of the tube should be placed in the chemical container above the fluid level.

5. START-UP

5.1 Priming the Pump

Plug in the pump, set the stroke to 100%, and set the strokes per minute to maximum speed. While the pump is operating, if fluid begins moving, no further priming is required. If fluid is not moving on the PVDF version, open the bleed valve approximately one turn until fluid begins to move. When the suction line fills, close the bleed valve. Do not over-tighten the bleed valve. Damage may occur. If fluid is not moving on the SS316 version, slightly unscrew the discharge check from the head to release any trapped air. Take proper safety precautions to protect yourself from possible chemical spray before executing this step. Once a consistent drip of fluid without any air bubbles is observed, properly retighten the discharge check.

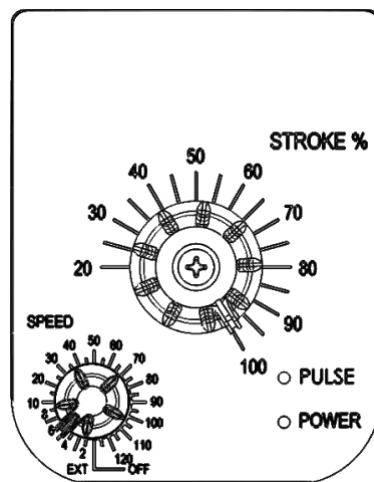

5.2 Adjusting the Feed Rate

The standard Series S allows for the exact setting of the pumps stroking rate (speed) on the pump's control panel. Standard strokes per minute settings available are: 2, 3, 4, 5, 6, 7, 8, 10 and increase by 5 thereafter, up to the maximum of 125.

5.3 Stroke Length

The stroke length can be adjusted on all Series S pumps. This adjustment is a mechanical adjustment made using the large knob on the control panel. **To avoid damage to the pump, this adjustment should only be made while the pump is running at a high stroking rate.**

WARNING: ONLY ADJUST STROKE % WHILE PUMP IS RUNNING A SPEED!

5.4 Calculating Output

A pump's output per minute can be determined by dividing the maximum rated gallons per hour by 60 (minutes per hour). For example, a 1.25 gallon per hour (GPH) pump, at a maximum stroke length and speed setting of 125 strokes per minute (SPM), will pump 0.0208 gallons per minute (GPM) and 0.000167 gallons per stroke.

$$1.25 \text{ GPH} \div 60 = 0.0208 \text{ GPM} \div 125 \text{ SPM} = 0.000167 \text{ GALLONS PER STROKE.}$$

With this value and the pump's speed setting (strokes per minute) you can calculate your pump's output at it's rated pressure. A 1.25 GPH pump set at 50 strokes per minute:

$$50 \text{ SPM} \times .000167 \text{ GALLONS PER STROKE} \times 60 \text{ MINUTES PER HOUR} = 0.501 \text{ GALLONS PER HOUR}$$

Reducing the stroke length will reduce the pump's output again. If the pump from the example above had its stroke length reduced to 50%, the 0.501 gallons per hour output is reduced to 0.250. (Example: 0.501 GPH x 0.50 = 0.250 GPH)

A higher product viscosity will reduce the output. Pressures lower than the pump's rating can increase the output.

5.5 Optimal Features

The following options are not standard. Contact CheckPoint to discuss your application when choosing options.

5.5.1 External Pacing

The external pacing option allows the speed of the pump to be controlled by an external device like a flow meter that gives dry contact switch closures. The pump sends out a 5-volt DC current to read a switch closure. Each time the pump sees the switch closure it strokes once, up to its maximum strokes per minute rate.

5.5.2 External Stop

Pumps with this option are allowed to stroke as long as they see a closed condition from a dry contact source like a flow switch or drum level wand. When an open condition is seen the pump is not allowed to stroke.

6. MAINTENANCE

The CheckPoint Series S pump is designed for long service life with minimum maintenance. If for any reason, maintenance is necessary or desirable, the Series S pump is easily maintained. Before any maintenance or service is performed, observe the following precautions:

1. Disconnect the Series S pump from power source.
2. Drain chemical from discharge tubing.
3. Disconnect discharge tubing from pump.
4. If the Series S pump is used in a flooded suction application, remove foot valve from chemical container.
5. Observe relevant safety protocols when handling parts which have been in contact with hazardous chemicals.

6.1 Diaphragm Replacement

1. Remove fluid end cover by lightly prying it loose from the fluid end.
2. Remove the four screws attaching the fluid end to pump body.
3. Remove the fluid end from the pump body.
4. Unscrew the diaphragm from the pump shaft in a counter-clockwise direction. Be careful that diaphragm support ring does not fall out.
5. Do not allow sharp or abrasive objects to come in contact with pump parts.
6. Inspect end of shaft to assure that threads are in good condition. Replace shaft bellows if necessary. No further disassembly is recommended.
7. Screw new diaphragm onto pump shaft until it bottoms out on shoulder of shaft. It is not necessary to tighten further.
8. Replace fluid end. Make sure that screws are evenly tightened.
9. Reconnect plumbing and power. Prime the pump.

6.2 Suction and Discharge Check Valve Replacement

PVDF Head

1. Disconnect suction tubing from pump.
2. Unscrew fitting from pump head.
3. Remove check valve from suction fitting and replace.
4. Remove O-ring from cavity in fluid end.
5. Remove check valve from suction side pump and replace.
6. Install new O-ring in cavity of fluid end.
7. Replace valve fitting with check valve in fluid end.
8. Replace fluid end. Make sure that screws are evenly tightened.
9. Reconnect plumbing and power. Prime the pump.

SS316 Head

1. Disconnect suction tubing from pump.
2. Unscrew suction and discharge check valves from pump head.
3. Screw in new suction and discharge check valves into pump head with Teflon tape as needed.
4. Reconnect suction and discharge tubing to check valves with Teflon tape as needed.
5. Reconnect plumbing and power. Prime the pump.

NOTE: Tighten pump head screws after pump's initial week of operation.

NOTE: When installing check valves, remember that the seats are always installed at the bottom.

6.3 PVDF Liquid End Diagram

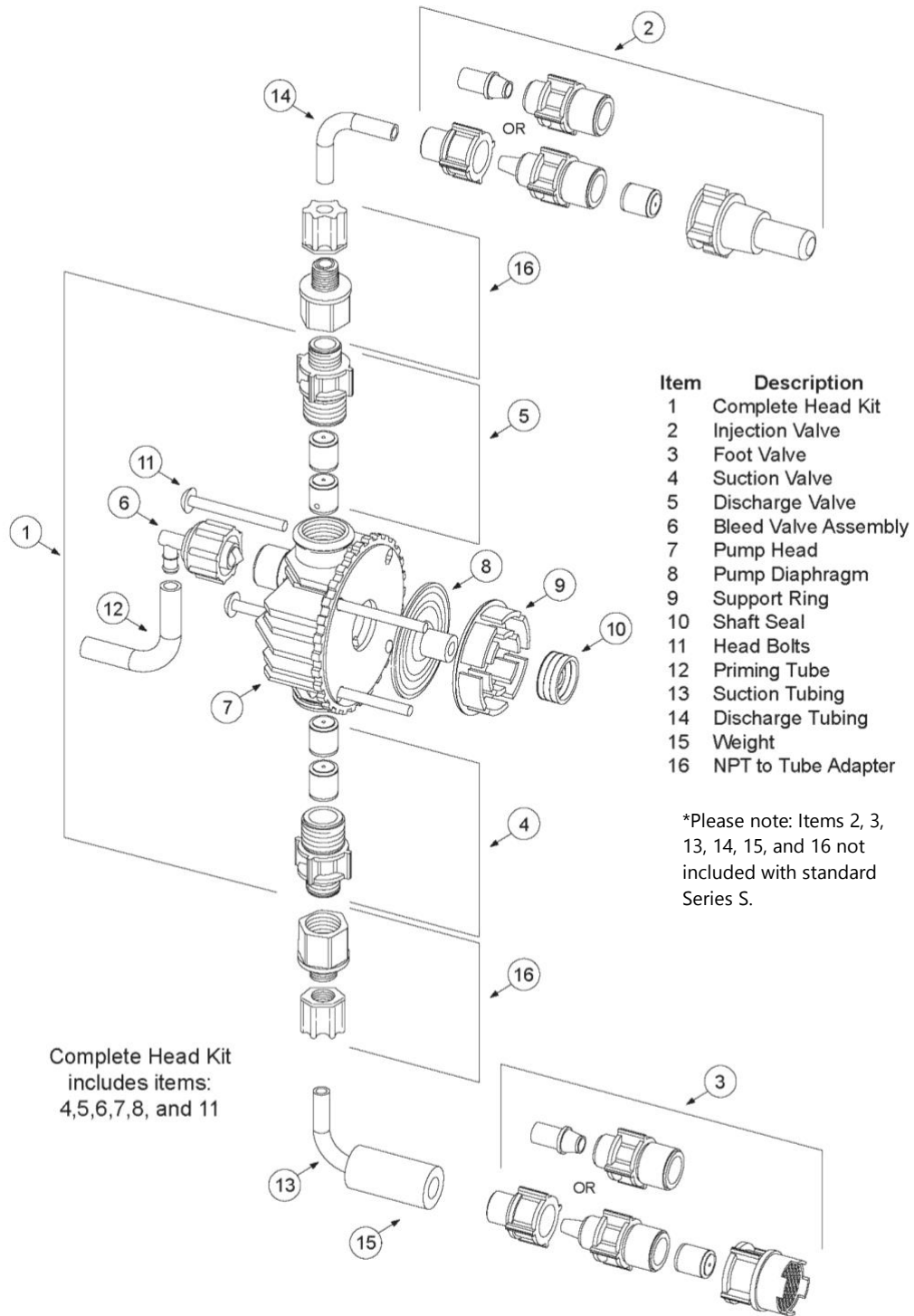

6.4 SS316 Liquid End Diagram

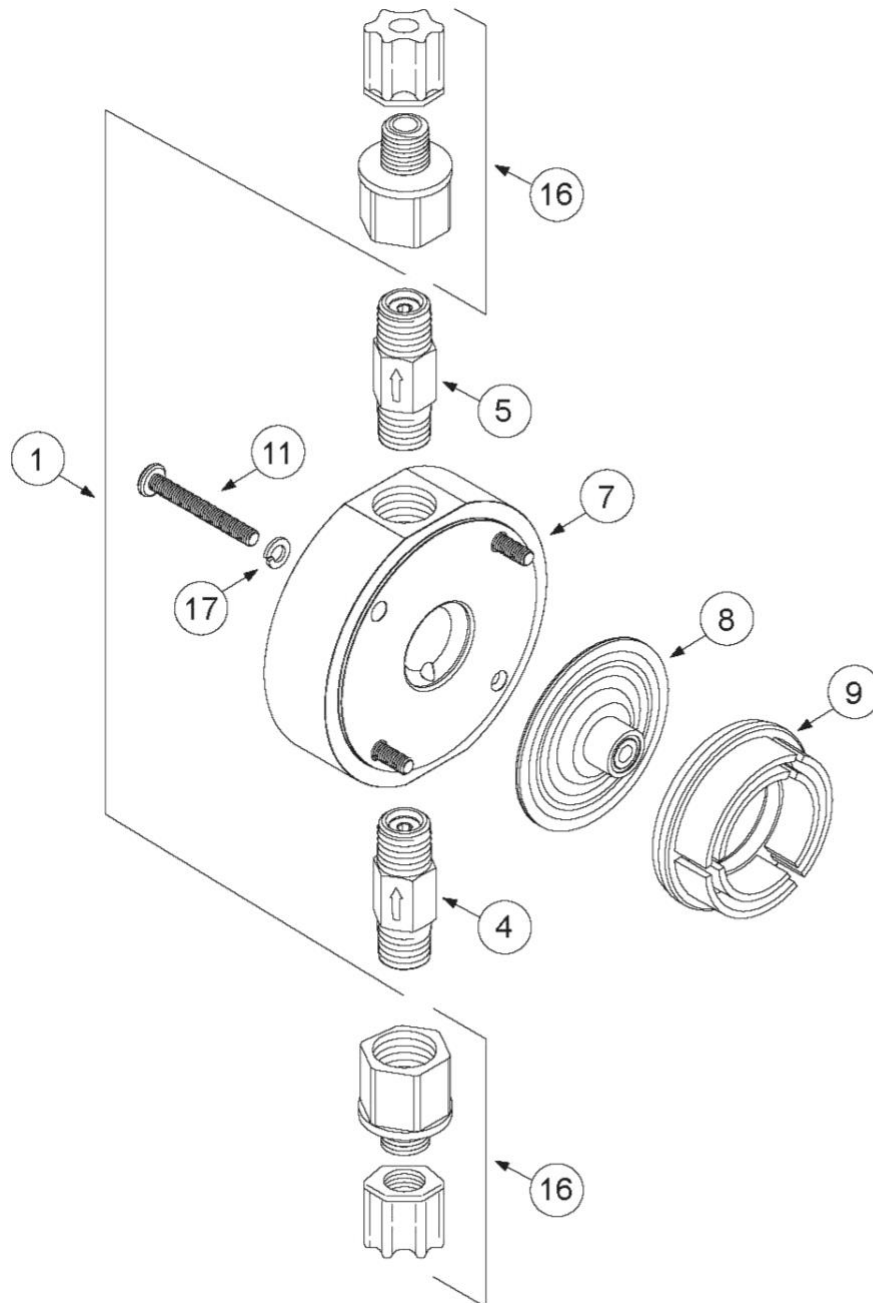

Item	Description
1	Complete Head Kit
4	Suction Valve
5	Discharge Valve
7	Pump Head
8	Pump Diaphragm
9	Support Ring
11	Head Bolts
16	NPT to Tube Adapter
17	Lock Washer

*Please note: Item 16, not included with standard Series S.

Complete Head Kit
includes items:
4,5,7,8,11 and 17

6.5 Replacement Parts

Getting the right materials of construction for your spare parts is easy. Using positions 7-9 of the pump model number, example: S1072PCTA10. Find the assembly needed and add the codes of your pump's liquid end after the standard prefix part number for the assembly. Reference Liquid End diagrams above to match item descriptions.

Part Assemblies

Item	Description	Part Number
1	Head Assembly, 0.5" Diaphragm (X041, X061, X072), PVDF, Bleed Valve, Head Bolts, Teflon Seals, Ceramic Ball Checks, 1/4" MNPT	S-HSA-05-PCT
	Head Assembly, 0.9" Diaphragm (X121), PVDF, Bleed Valve, Head Bolts, Teflon Seals, Ceramic Ball Checks, 1/4" MNPT	S-HSA-09-PCT
	Head Assembly, 0.5" Diaphragm (X041, X061, X072), SS316, Head Bolts, Teflon Seals, SS316 Ball Checks, 1/4" MNPT	S-HSA-05-SST
2	Injection Valve Assembly, PVDF, Teflon, Ceramic Ball, 1/4" MNPT	S-INJ-PCT
	3-Function Injection Valve, PVDF, Teflon, Ceramic Ball, 1/4" MNPT	S-3FV-PCT
3	Foot Valve Assembly, PVDF, Ceramic Ball, 1/4" Tube Connection	S-FTV-PCT2
4	Suction Check Valve Assembly, PVDF, Ceramic Ball, 1/4" MNPT	S-SUC-PCT
	Check Valve Assembly, SS316, SS316 Ball, 1/4" MNPT	S-CV-SST
5	Discharge Check Valve Assembly, PVDF, Ceramic Ball, 1/4" MNPT	S-DIS-PCT
	Check Valve Assembly, SS316, SS316 Ball, 1/4" MNPT	S-CV-SST
6	Priming Valve Assembly, PVDF, Teflon, Ceramic, 3/8" Tube Connection	S-PVA-PCT1

Single Parts

Item	Description	Part Number
7	Head, 0.5" (X041, X061, X072), PVDF	S-HEAD-05-PCT
	Head, 0.9" (X121), PVDF	S-HEAD-09-PCT
	Head, 0.5" (X041, X061, X072), SS316, T-Style	S-HEAD-05-SST
8	Diaphragm, 0.5", Teflon Coated Neoprene	S-DIA-05
	Diaphragm, 0.9", Teflon Coated Neoprene	S-DIA-09
9	Support Ring, 0.5"	S-00068
	Support Ring, 0.9"	S-00069
10	Shaft Seal, solenoid through housing	S-00050
11	Head Bolts / Screws	S-00045
12	Priming Tubing 3/8" Clear	S-00255
13	Suction Tubing 3/8" Clear	S-00255
	Suction Tubing 3/8" PE	S-00122
	Suction Tubing 1/4" PE	S-00097
14	Discharge Tubing 3/8" PE	S-00122
	Discharge Tubing 1/4" PE	S-00267
15	Weight, Suction Tubing, Ceramic	S-00139
16	3/8 Tube X 1/4 FNPT Female Straight Connector, PVDF	FTK6FSC4N
	1/4 Tube X 1/4 FNPT Female Straight Connector, PVDF	FTK4FSC4N

7. TROUBLESHOOTING

PROBLEM	CAUSE	REMEDY
Pump does not achieve or maintain prime	Air trapped in suction line	Straighten suction line so as to eliminate high spots.
	Foot valve contaminated or improperly installed	Inspect foot valve screen and assure that foot valve is in a vertical position below fluid level.
	Excessive lift	Maximum suction lift is 5 feet with water or fluids of similar specific gravity; less with heavier liquids such as acids. Mount pump in a lower position relative to the chemical container.
	Suction fittings not properly tightened	Check fittings. Overtightening may cause restriction. Conversely, if any leakage occurs, pump will suck air and fail to prime.
	Worn or contaminated check valves	Inspect check valves in fluid end for cleanliness. Clean or replace as necessary.
	Split or pinch in suction tube	Inspect suction tube through its full length to assure that there are no splits at the connections or other restrictions. Move any objects or equipment which impinges upon suction tube or reroute as required to assure a smooth transition from foot valve to pump.
	Low chemical level	Check fluid level in chemical supply tank.
Insufficient fluid	Stroke adjustment set too low	Check operation of stroke limiter knob. If pump delivers too low adjustable rate, check settings. Readjust as required.
	Worn or contaminated check valves	Inspect, clean or replace as necessary.
	Obstruction in suction line	Check suction line for obstructions, clogging, kinks or pinch points.
	Clogged foot valve screen	Clean or replace foot valve screen.
	Output (system) pressure too high	Relocate the injector to a lower pressure part of the system.
	Diaphragm worn or torn	Replace diaphragm, making sure that it is screwed on fully to shoulder of shaft.
	Electronic failure	Consult dealer or factory.

PROBLEM	CAUSE	REMEDY
Excessive fluid	Failure or lack of anti-siphon valve	Inspect or add anti-siphon valve. This is caused when system is in a vacuum condition or valve in delivery applications with flooded suction which feeds systems at very low pressures.
	Excessive stroke rate	Lower the stroke rate if adjustable on your pump.
	Improper stroke length	Reduce stroke length.
Pump will not pump	System pressure too high	Check system pressure to assure that it is within system rated parameters of the pressure.
	Diaphragm improperly installed	Make sure that diaphragm is screwed fully unto shaft.
	Check valves worn or clogged	Clean or replace as required.
Pump will not run not plugged in	Pump not turned on or not plugged in	Check outlet with meter to assure that correct or voltage is present and that power supply cord is in good condition and plugged in.
	Electronic failure	Consult dealer or factory.
Excessive noise	Pump not primed	Prime pump.
	No output pressure	Add an anti-siphon valve to provide 25 PSI restriction on pump discharge.

