

PART #	MATERIAL
MK-ATP31CSA304YHQF	HLC-FKM-FFKM

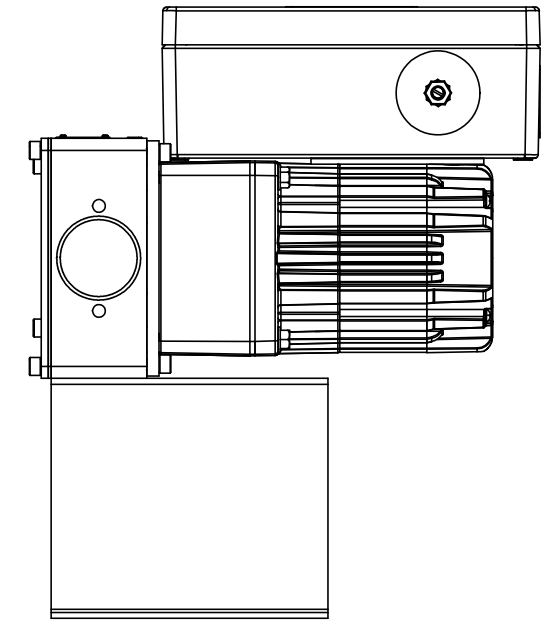

-- DO NOT SCALE DRAWING --

CheckPoint Pumps & Systems	
DWG. TITLE	
1 PUMP 1 HEAD ASSEMBLY ATP 3	
REV	SIZE
00	B
DRAWING NUMBER	
SHEET 1 OF 2	

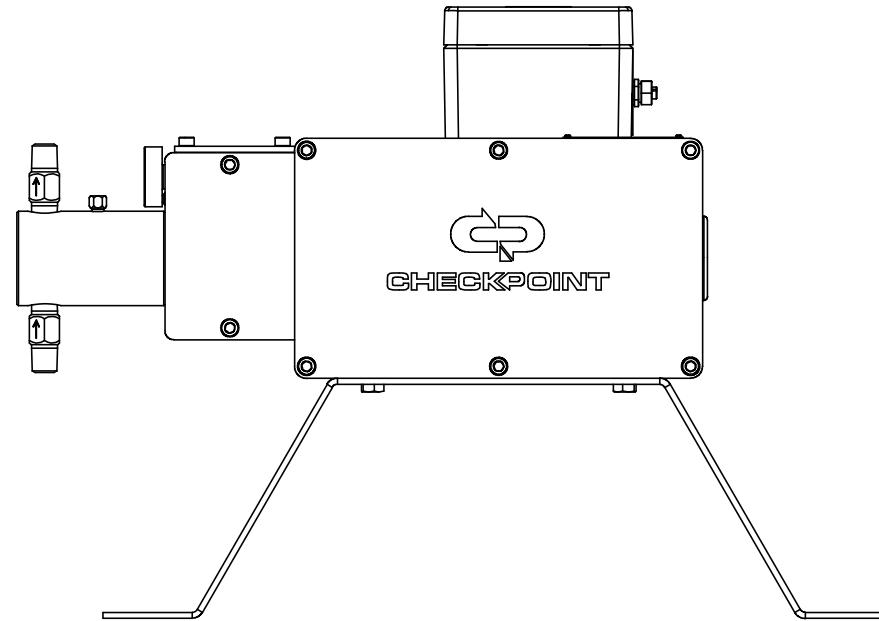
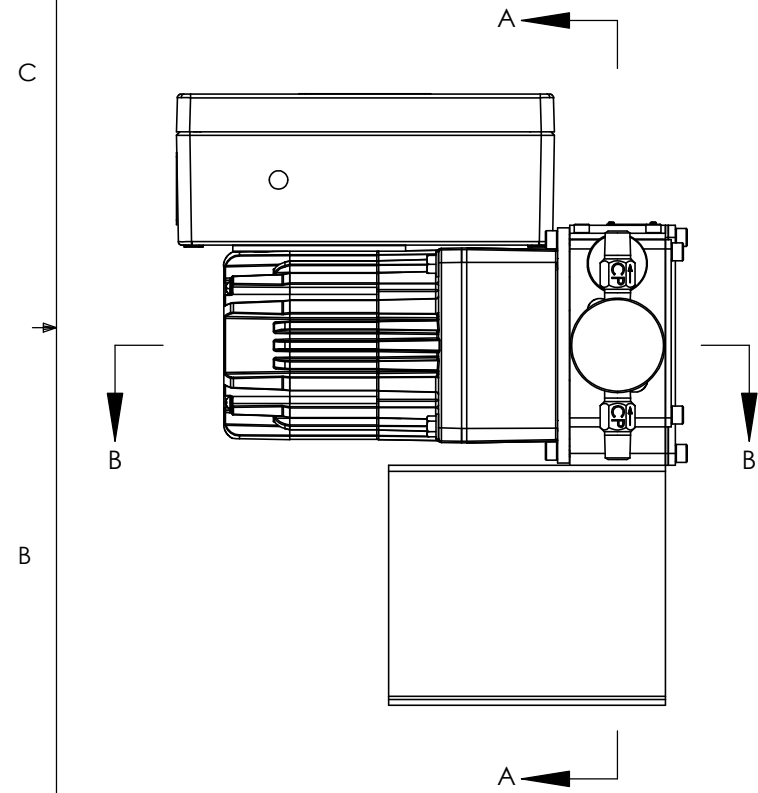
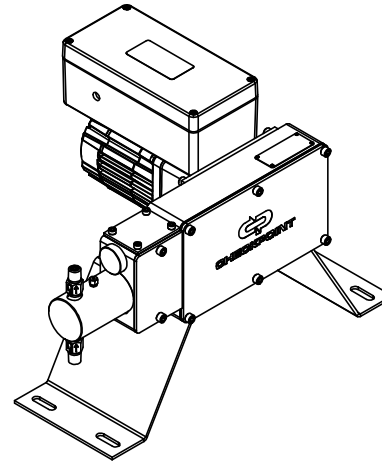

UNLESS OTHERWISE SPECIFIED:
DIMENSIONS ARE IN INCHES AND
RADII = 0.015

TOLERANCES:
ANGULAR: ± 0.5 deg
DECIMAL:
.xx ±.010 .xxx ±.005

125/ 63/

	NAME	DATE
DRAWN	J.FERRILL	01/19/23
CHECKED	A.CANIK	01/19/23
ENG APPR.	W. SCHNECK	01/19/23
MFG APPR.	M. LOVAS	01/19/23
Q.A.	T. DAMICO	01/19/23

PROPRIETARY AND CONFIDENTIAL
THE INFORMATION CONTAINED HEREIN IS PROPRIETARY TO CHECKPOINT SYSTEMS AND SHALL NOT BE REPRODUCED OR DISCLOSED IN WHOLE OR IN PART OR USED FOR ANY PURPOSE EXCEPT WHEN SUCH USER POSSESSES DIRECT WRITTEN AUTHORIZATION FROM CHECKPOINT SYSTEMS

ATP31CS-A304YH - HLC

ITEM NO.	Number	DESCRIPTION	QTY.
1	ATP0100-01	ATP SERIAL # PLATE	1
2	ATP0160-01	PUMP STAND	1
3	ATP0583-010	MOTOR ADAPTER	1
4	ATPC0011-01	ATP CORE	1
5	FASHH-0100	BOLT	2
6	FASSH-0101	SCREW	4
7	ORPF2104	O RING	1
8	P2551	U-DRIVE SCREW	4
9	SFHS8042810	SCREW	4
10	SOLR0009-307M	DC Motor	1
11	WATM304YNHBY3-6	WET END ASSY	1

ATP31CS-A304YQ - FKM

ITEM NO.	NUMBER	DESCRIPTION	QTY.
1	ATP0100-01	ATP SERIAL # PLATE	1
2	ATP0160-01	PUMP STAND	1
3	ATP0583-010	MOTOR ADAPTER	1
4	ATPC0011-01	ATP CORE	1
5	FASHH-0100	BOLT	2
6	FASSH-0101	SCREW	4
7	ORPF2104	O RING	1
8	P2551	U-DRIVE SCREW	4
9	SFHS8042810	SCREW	4
10	SOLR0009-307M	DC Motor	1
11	WATM304YNQBY3-6	WET END ASSY	1

ATP31CS-A304YF - FFKM

ITEM NO.	NUMBER	DESCRIPTION	QTY.
1	ATP0100-01	ATP SERIAL # PLATE	1
2	ATP0160-01	PUMP STAND	1
3	ATP0583-010	MOTOR ADAPTER	1
4	ATPC0011-01	ATP CORE	1
5	FASHH-0100	BOLT	2
6	FASSH-0101	SCREW	4
7	ORPF2104	O RING	1
8	P2551	U-DRIVE SCREW	4
9	SFHS8042810	SCREW	4
10	SOLR0009-307M	DC Motor	1
11	WATM304YNFBY3-6	WET END ASSY	1

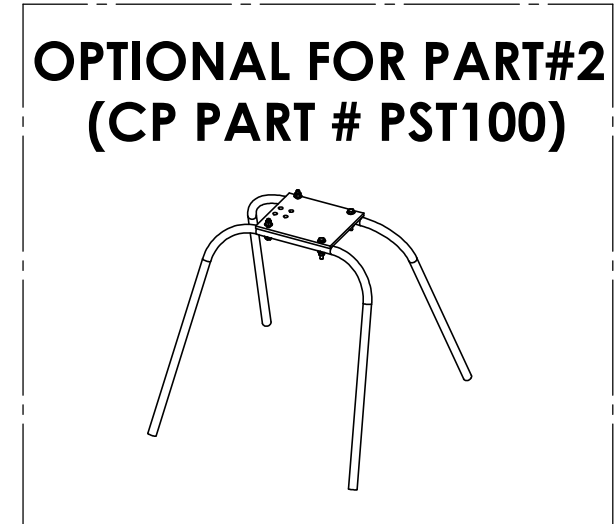
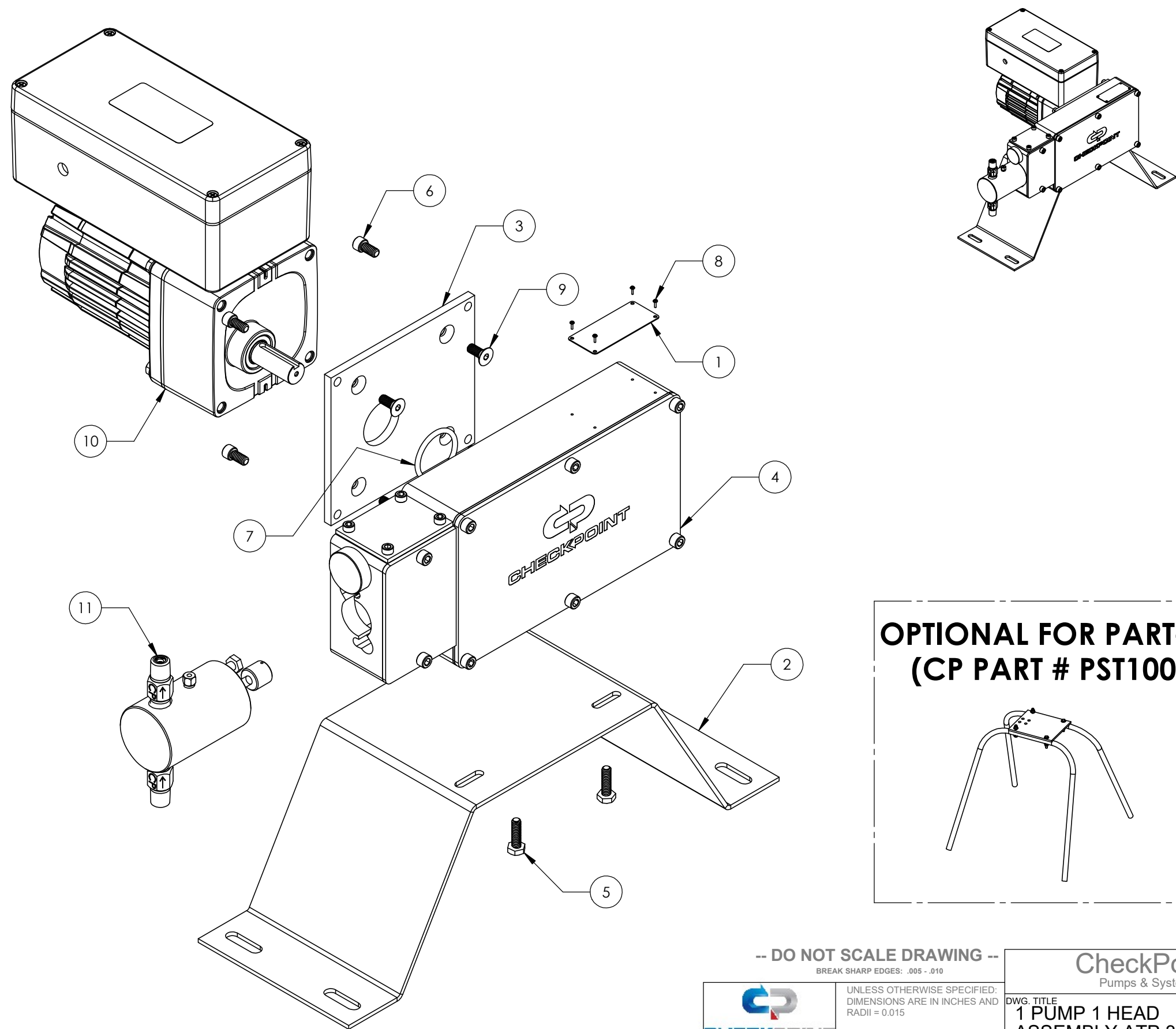

-- DO NOT SCALE DRAWING --
BREAK SHARP EDGES: .005 - .010



UNLESS OTHERWISE SPECIFIED:
DIMENSIONS ARE IN INCHES AND
RADII = 0.015

TOLERANCES:
ANGULAR: ± 0.5 deg
DECIMAL:
.xx ±.010 .xxx ±.005

125/63

CheckPoint Pumps & Systems	
DWG. TITLE 1 PUMP 1 HEAD ASSEMBLY ATP 3	
REV 00	SIZE B
DRAWING NUMBER MK-ATP31CSA304YHQF	
SHEET 2 OF 2	

PROPRIETARY AND CONFIDENTIAL
THE INFORMATION CONTAINED HEREIN IS PROPRIETARY TO CHECKPOINT SYSTEMS AND SHALL NOT
BE REPRODUCED OR DISCLOSED IN WHOLE OR IN PART OR USED FOR ANY PUPOSE EXCEPT WHEN
SUCH USER POSSESSES DIRECT WRITTEN AUTHORIZATION FROM CHECKPOINT SYSTEMS

PART #	MATERIAL
MK-ATP31CSA306YHQF	HLC - FKM - FFKM

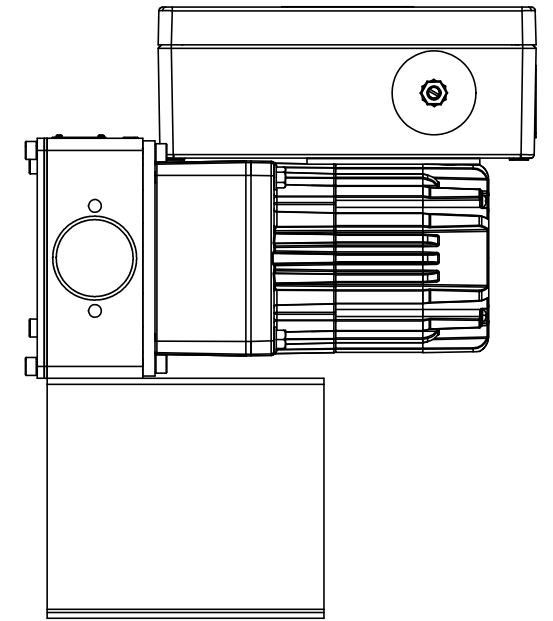
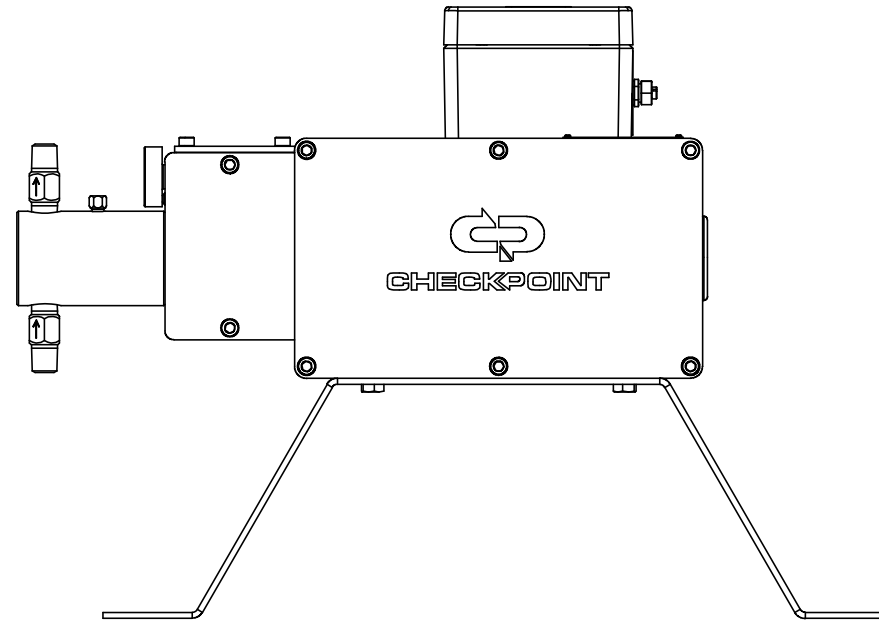
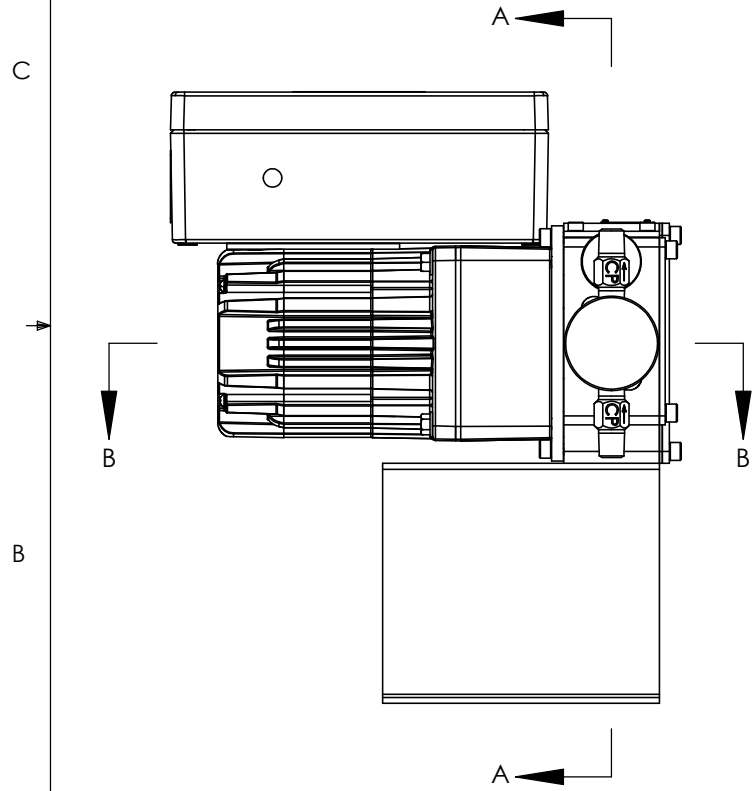
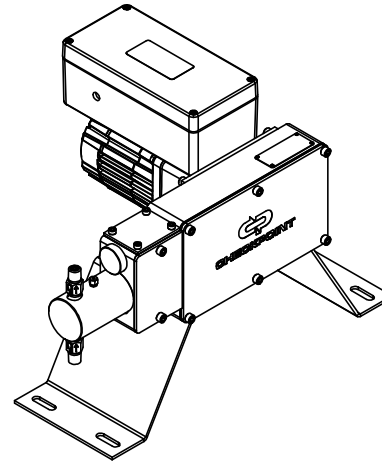

-- DO NOT SCALE DRAWING --

CheckPoint
Pumps & Systems



UNLESS OTHERWISE SPECIFIED:
DIMENSIONS ARE IN INCHES AND
RADII = 0.015

TOLERANCES:
ANGULAR: ± 0.5 deg
DECIMAL:
.xx $\pm .010$.xxx $\pm .005$

125/ 63/

	NAME	DATE
DRAWN	J.FERRILL	01/19/23
CHECKED	A.CANIK	01/19/23
ENG APPR.	W. SCHNECK	01/19/23
MFG APPR.	M. LOVAS	01/19/23
Q.A.	T DAMICO	01/19/23

DWG. TITLE		REV	SIZE
1 PUMP 1 HEAD ASSEMBLY ATP 3			
00	MK-ATP31CSA306YHQF		B
DRAWING NUMBER		SHEET 1 OF 2	

PROPRIETARY AND CONFIDENTIAL
THE INFORMATION CONTAINED HEREIN IS PROPRIETARY TO CHECKPOINT SYSTEMS AND SHALL NOT BE REPRODUCED OR DISCLOSED IN WHOLE OR IN PART OR USED FOR ANY PUPOSE EXCEPT WHEN SUCH USER POSSESSES DIRECT WRITTEN AUTHORIZATION FROM CHECKPOINT SYSTEMS

ATP31CS-A306YH - HLC

ITEM NO.	Number	DESCRIPTION	QTY.
1	ATP0100-01	ATP SERIAL # PLATE	1
2	ATP0160-01	PUMP STAND	1
3	ATP0583-010	MOTOR ADAPTER	1
4	ATPC0011-01	ATP CORE	1
5	FASHH-0100	BOLT	2
6	FASSH-0101	SCREW	4
7	ORPF2104	O RING	1
8	P2551	U-DRIVE SCREW	4
9	SFHS8042810	SCREW	4
10	SOLR0009-307M	DC Motor	1
11	WATM306YNHBY3-6	WET END ASSY	1

ATP31CS-A306YQ - FKM

ITEM NO.	NUMBER	DESCRIPTION	QTY.
1	ATP0100-01	ATP SERIAL # PLATE	1
2	ATP0160-01	PUMP STAND	1
3	ATP0583-010	MOTOR ADAPTER	1
4	ATPC0011-01	ATP CORE	1
5	FASHH-0100	BOLT	2
6	FASSH-0101	SCREW	4
7	ORPF2104	O RING	1
8	P2551	U-DRIVE SCREW	4
9	SFHS8042810	SCREW	4
10	SOLR0009-307M	DC Motor	1
11	WATM306YNQBY3-6	WET END ASSY	1

ATP31CS-A306YF - FFKM

ITEM NO.	NUMBER	DESCRIPTION	QTY.
1	ATP0100-01	ATP SERIAL # PLATE	1
2	ATP0160-01	PUMP STAND	1
3	ATP0583-010	MOTOR ADAPTER	1
4	ATPC0011-01	ATP CORE	1
5	FASHH-0100	BOLT	2
6	FASSH-0101	SCREW	4
7	ORPF2104	O RING	1
8	P2551	U-DRIVE SCREW	4
9	SFHS8042810	SCREW	4
10	SOLR0009-307M	DC Motor	1
11	WATM306YNFBY3-6	.375 IN HEAD	1

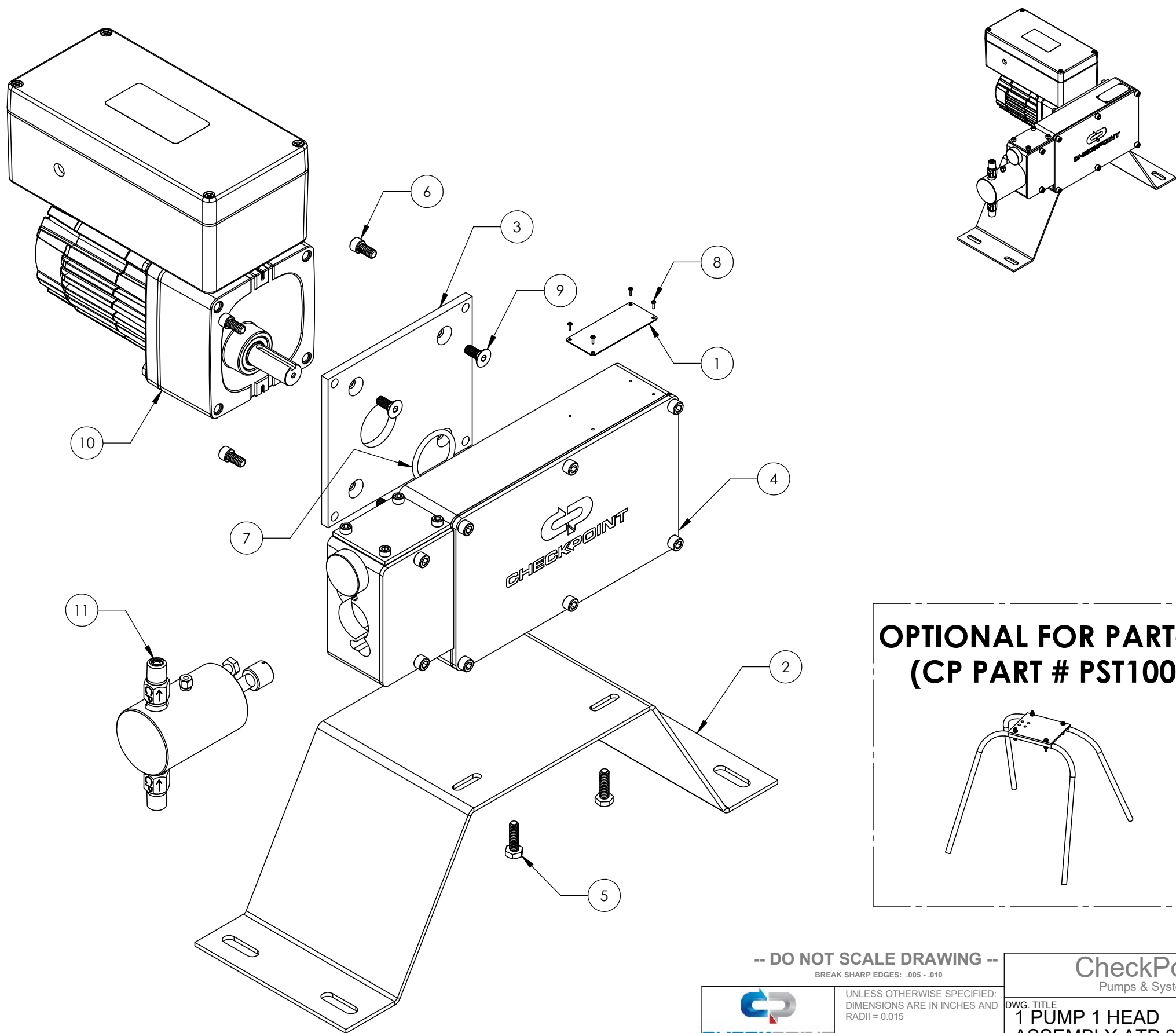

**OPTIONAL FOR PART#2
(CP PART # PST100)**

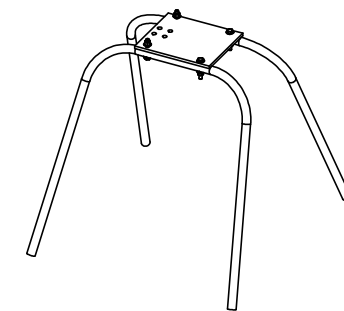

-- DO NOT SCALE DRAWING --
BREAK SHARP EDGES: .005 - .010



UNLESS OTHERWISE SPECIFIED:
DIMENSIONS ARE IN INCHES AND
RADII = 0.015

TOLERANCES:
ANGULAR: ± 0.5 deg
DECIMAL:
.xx ±.010 .xxx ±.005

125 63

CheckPoint Pumps & Systems	
DWG. TITLE 1 PUMP 1 HEAD ASSEMBLY ATP 3	
REV 00	SIZE B
DRAWING NUMBER MK-ATP31CSA306YHQF	
SHEET 2 OF 2	

PROPRIETARY AND CONFIDENTIAL
THE INFORMATION CONTAINED HEREIN IS PROPRIETARY TO CHECKPOINT SYSTEMS AND SHALL NOT
BE REPRODUCED OR DISCLOSED IN WHOLE OR IN PART OR USED FOR ANY PUPOSE EXCEPT WHEN
SUCH USER POSSESSES DIRECT WRITTEN AUTHORIZATION FROM CHECKPOINT SYSTEMS

PART #	MATERIAL
MK-ATP31CSA308YHQF	HLC - FKM - FFKM

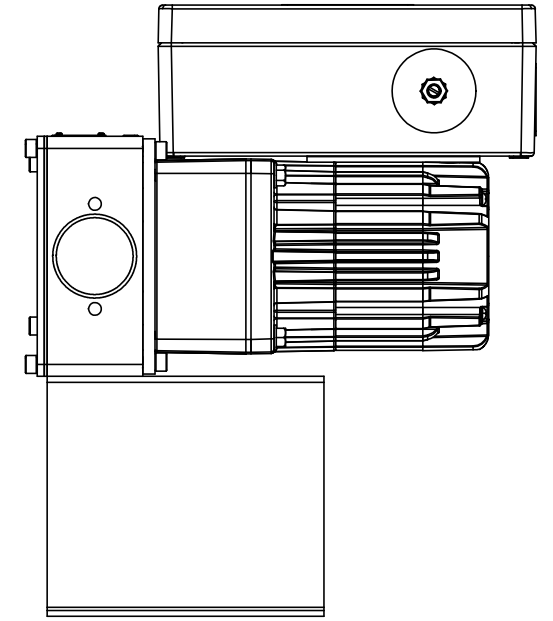
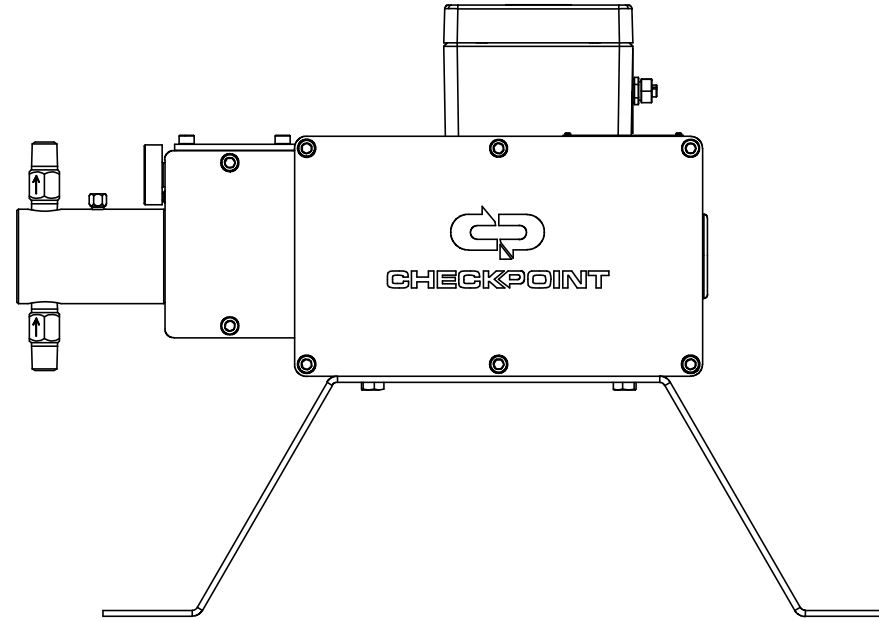
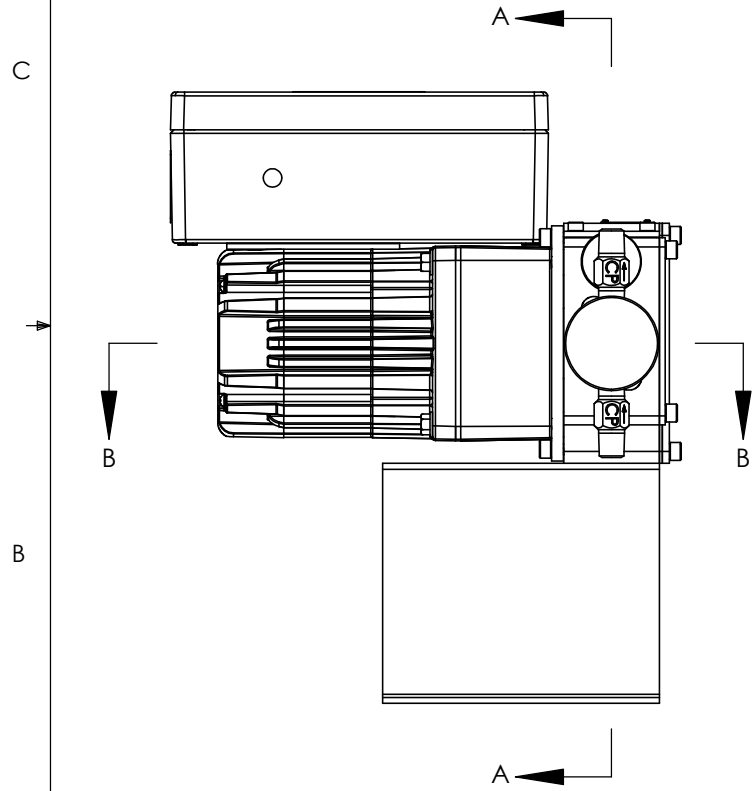
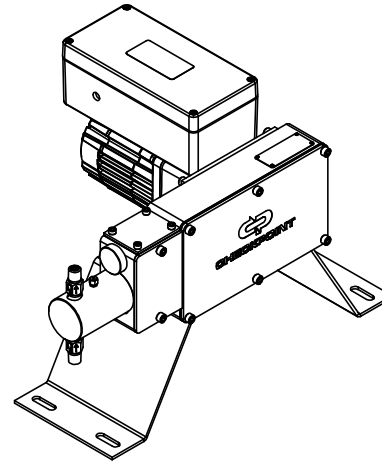

-- DO NOT SCALE DRAWING --

CheckPoint
Pumps & Systems



UNLESS OTHERWISE SPECIFIED:
DIMENSIONS ARE IN INCHES AND
RADII = 0.015

TOLERANCES:
ANGULAR: ± 0.5 deg
DECIMAL:
.xx ± 0.10 .xxx ± 0.05

125/ 63/

	NAME	DATE
DRAWN	J.FERRILL	01/19/23
CHECKED	A.CANIK	01/19/23
ENG APPR.	W. SCHNECK	01/19/23
MFG APPR.	M. LOVAS	01/19/23
Q.A.	T. DAMICO	01/19/23

DWG. TITLE		REV	SIZE
1 PUMP 1 HEAD ASSEMBLY ATP 3			
00	MK-ATP31CSA308YHQF		B
DRAWING NUMBER		SHEET 1 OF 2	

PROPRIETARY AND CONFIDENTIAL
THE INFORMATION CONTAINED HEREIN IS PROPRIETARY TO CHECKPOINT SYSTEMS AND SHALL NOT BE REPRODUCED OR DISCLOSED IN WHOLE OR IN PART OR USED FOR ANY PUPOSE EXCEPT WHEN SUCH USER POSSESSES DIRECT WRITTEN AUTHORIZATION FROM CHECKPOINT SYSTEMS

ATP31CS-A308YH - HLC

ITEM NO.	Number	DESCRIPTION	QTY.
1	ATP0100-01	ATP SERIAL # PLATE	1
2	ATP0160-01	PUMP STAND	1
3	ATP0583-010	MOTOR ADAPTER	1
4	ATPC0011-01	ATP CORE	1
5	FASHH-0100	BOLT	2
6	FASSH-0101	SCREW	4
7	ORPF2104	O RING	1
8	P2551	U-DRIVE SCREW	4
9	SFHS8042810	SCREW	4
10	SOLR0009-307M	DC Motor	1
11	WATM308YNHBY3-6	WET END ASSY	1

ATP31CS-A308YQ - FKM

ITEM NO.	NUMBER	DESCRIPTION	QTY.
1	ATP0100-01	ATP SERIAL # PLATE	1
2	ATP0160-01	PUMP STAND	1
3	ATP0583-010	MOTOR ADAPTER	1
4	ATPC0011-01	ATP CORE	1
5	FASHH-0100	BOLT	2
6	FASSH-0101	SCREW	4
7	ORPF2104	O RING	1
8	P2551	U-DRIVE SCREW	4
9	SFHS8042810	SCREW	4
10	SOLR0009-307M	DC Motor	1
11	WATM308YNQBY3-6	WET END ASSY	1

ATP31CS-A308YF - FFKM

ITEM NO.	NUMBER	DESCRIPTION	QTY.
1	ATP0100-01	ATP SERIAL # PLATE	1
2	ATP0160-01	PUMP STAND	1
3	ATP0583-010	MOTOR ADAPTER	1
4	ATPC0011-01	ATP CORE	1
5	FASHH-0100	BOLT	2
6	FASSH-0101	SCREW	4
7	ORPF2104	O RING	1
8	P2551	U-DRIVE SCREW	4
9	SFHS8042810	SCREW	4
10	SOLR0009-307M	DC Motor	1
11	WATM308YNFBY3-6	WET END ASSY	1

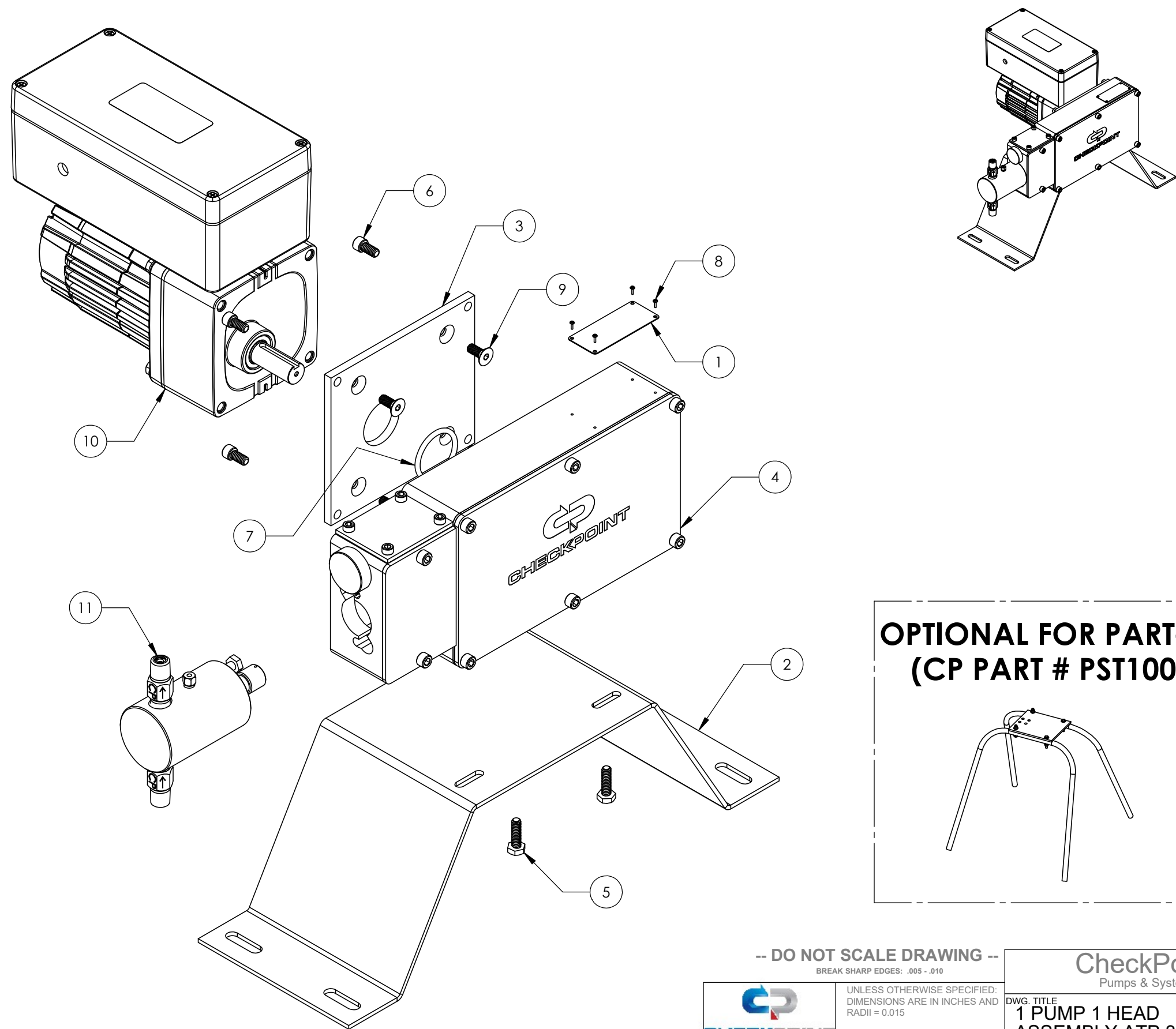

**OPTIONAL FOR PART#2
(CP PART # PST100)**

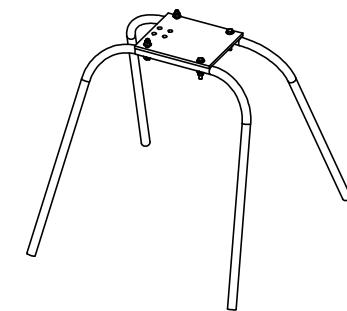

-- DO NOT SCALE DRAWING --
BREAK SHARP EDGES: .005 - .010



UNLESS OTHERWISE SPECIFIED:
DIMENSIONS ARE IN INCHES AND
RADII = 0.015

TOLERANCES:
ANGULAR: ± 0.5 deg
DECIMAL:
.xx ±.010 .xxx ±.005

125 63

CheckPoint Pumps & Systems	
DWG. TITLE 1 PUMP 1 HEAD ASSEMBLY ATP 3	
REV 00	SIZE B
DRAWING NUMBER MK-ATP31CSA308YHQF	
SHEET 2 OF 2	

PROPRIETARY AND CONFIDENTIAL
THE INFORMATION CONTAINED HEREIN IS PROPRIETARY TO CHECKPOINT SYSTEMS AND SHALL NOT
BE REPRODUCED OR DISCLOSED IN WHOLE OR IN PART OR USED FOR ANY PURPOSE EXCEPT WHEN
SUCH USER POSSESSES DIRECT WRITTEN AUTHORIZATION FROM CHECKPOINT SYSTEMS