

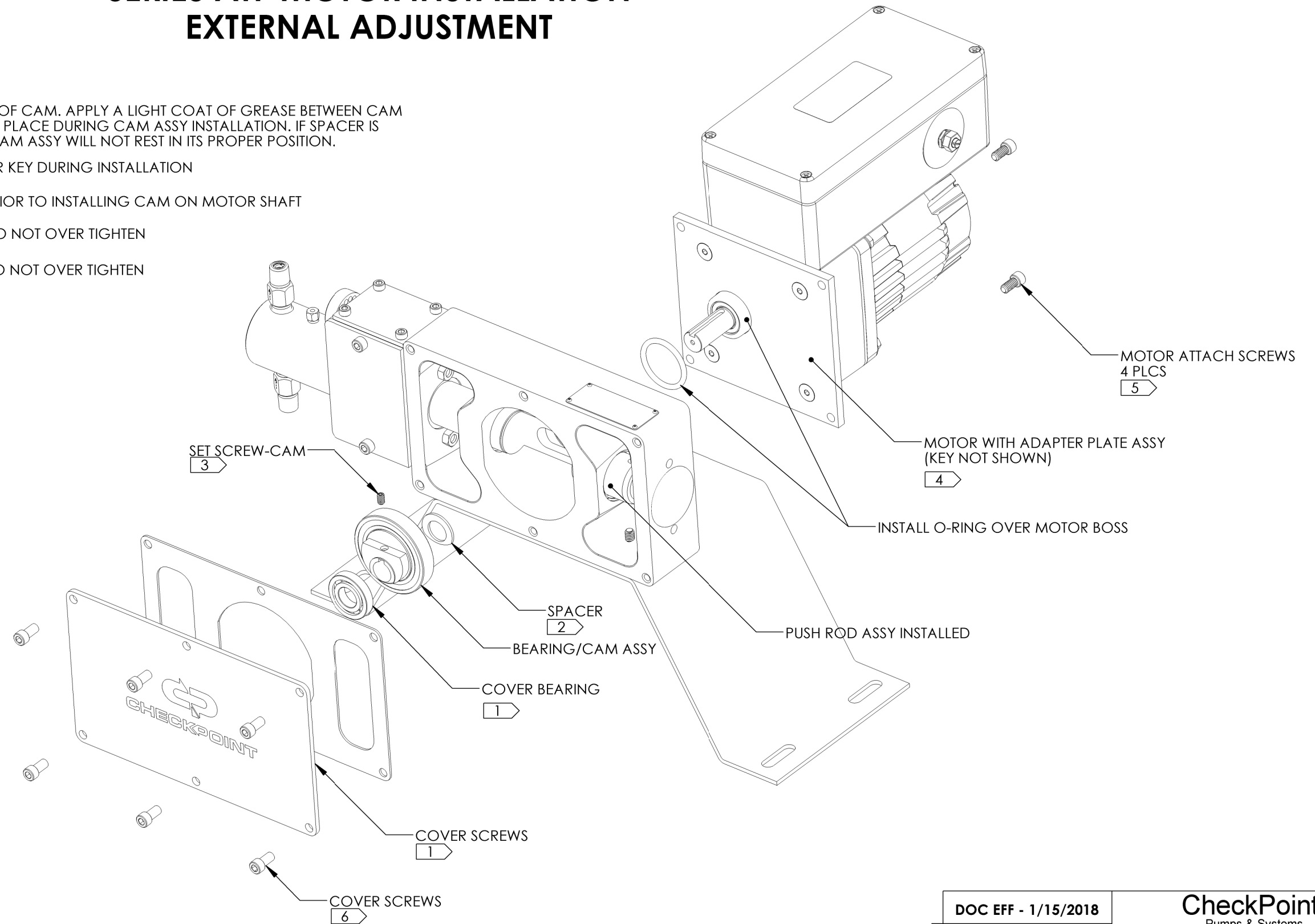

# SERIES ATP MOTOR INSTALLATION EXTERNAL ADJUSTMENT

- 1 INSERT BEARING IN FRONT COVER.
- 2 SPACER FITS IN RECESS ON BACK SIDE OF CAM. APPLY A LIGHT COAT OF GREASE BETWEEN CAM ASSY AND SPACER TO KEEP SPACER IN PLACE DURING CAM ASSY INSTALLATION. IF SPACER DOES NOT STAY IN CAM RECESS THE CAM ASSY WILL NOT REST IN ITS PROPER POSITION.
- 3 ENSURE SET SCREW CONTACTS MOTOR KEY DURING INSTALLATION
- 4 PUSH ROD ASSY MUST BE INSTALLED PRIOR TO INSTALLING CAM ON MOTOR SHAFT
- 5 TIGHTEN ATTACH SCREWS 25 IN LBS. DO NOT OVER TIGHTEN
- 6 TIGHTEN ATTACH SCREWS 15 IN LBS. DO NOT OVER TIGHTEN



**PROPRIETARY AND CONFIDENTIAL**  
 THE INFORMATION CONTAINED HEREIN IS PROPRIETARY TO CHECKPOINT SYSTEMS AND SHALL NOT BE REPRODUCED OR DISCLOSED IN WHOLE OR IN PART OR USED FOR ANY PURPOSE EXCEPT WHEN SUCH USER POSSESSES DIRECT WRITTEN AUTHORIZATION FROM CHECKPOINT SYSTEMS

**-- DO NOT SCALE DRAWING --**

DOC EFF - 1/15/2018	<b>CheckPoint</b> Pumps & Systems		
	DWG. TITLE <b>ATP MOTOR INSTL EXT ADJ - SINGLE</b>		
21356 MARION LANE MANDEVILLE, LA 70471 USA TEL 504.340.0770 -- FAX 888.217.6402	REV <b>00</b>	MKT - MTR INSTL - 3	SIZE <b>B</b>
DRAWING NUMBER	SHEET 1 OF 2		

8 7 6 5 4 3 2 1

D  
C  
B  
A

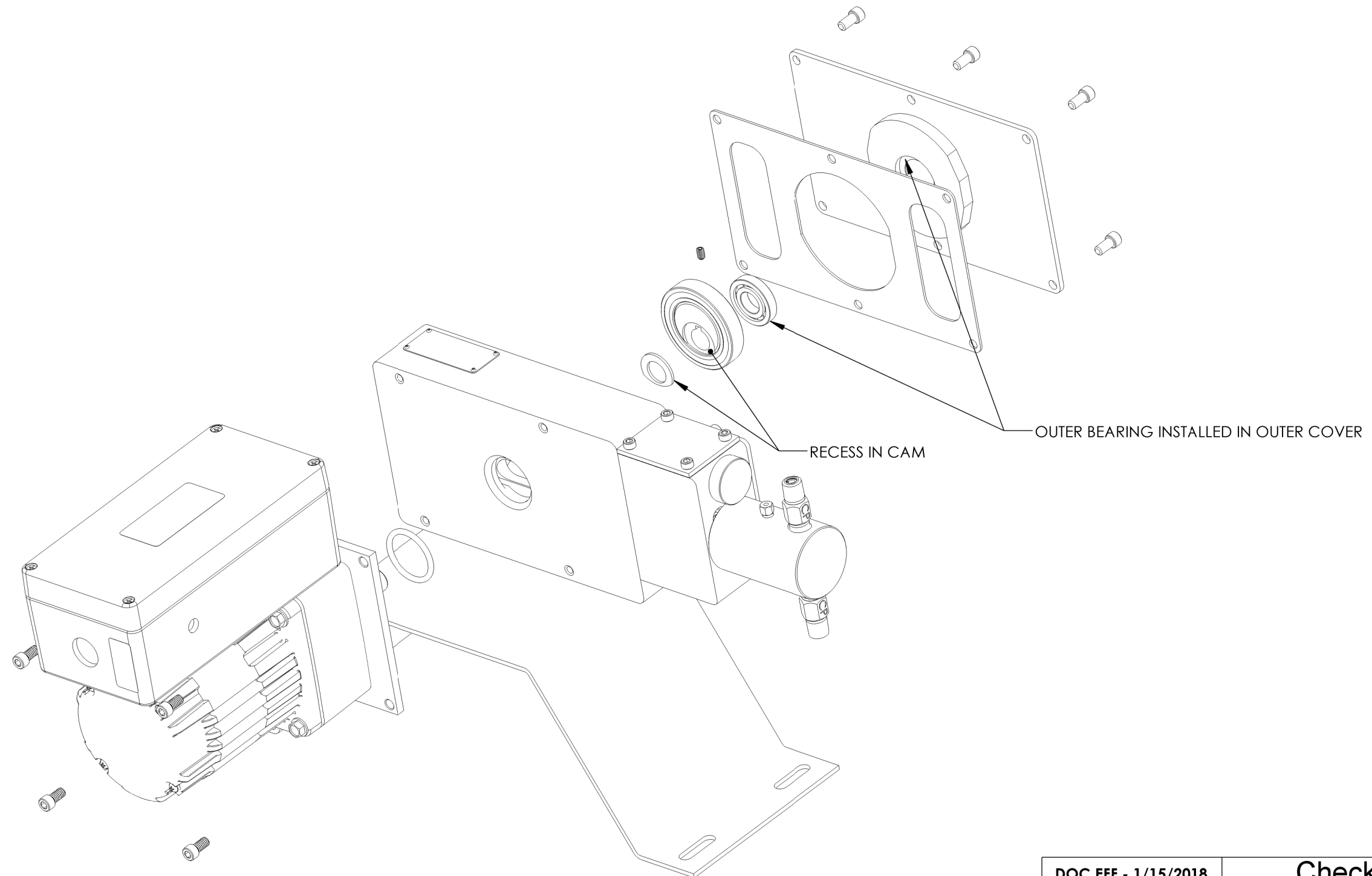

**PROPRIETARY AND CONFIDENTIAL**  
 THE INFORMATION CONTAINED HEREIN IS PROPRIETARY TO CHECKPOINT SYSTEMS AND SHALL NOT BE REPRODUCED OR DISCLOSED IN WHOLE OR IN PART OR USED FOR ANY PUPOSE EXCEPT WHEN SUCH USER POSSESSES DIRECT WRITTEN AUTHORIZATION FROM CHECKPOINT SYSTEMS

**-- DO NOT SCALE DRAWING --**

DOC EFF - 1/15/2018		<b>CheckPoint</b> Pumps & Systems	
DWG. TITLE <b>ATP MOTOR INSTL          EXT ADJ - SINGLE</b>			
REV <b>00</b>	<b>MKT - MTR INSTL - 3</b>	SIZE <b>B</b>	
DRAWING NUMBER		SHEET 2 OF 2	

6 5 4 3 2 1