

-- DO NOT SCALE DRAWING --

FOR REFERENCE ONLY  
CONTROLLED BY PDM



**CheckPoint**  
Pumps & Systems

DWG. TITLE  
TOP ASSEMBLY - 1/4"  
GX15

REV.	ASSY #	SIZE
6	GX15G12C3QLC34	A

DRAWING NUMBER

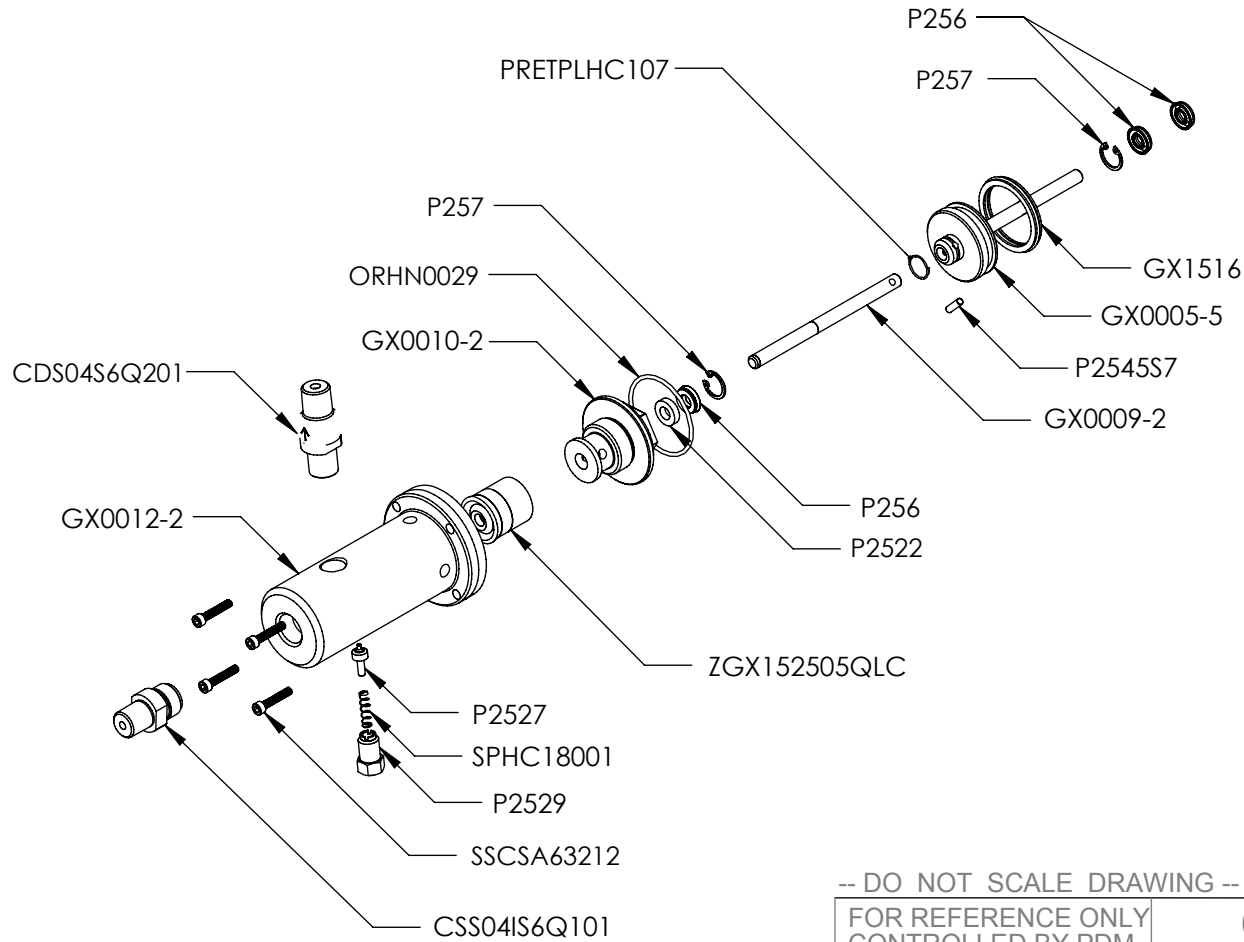

-- DO NOT SCALE DRAWING --

FOR REFERENCE ONLY  
CONTROLLED BY PDM



**CheckPoint**  
Pumps & Systems

DWG. TITLE

TOP ASSEMBLY - 1/4"  
GX15

REV.

6

ASSY #

GX15G12C3QLC34

SIZE

A

DRAWING NUMBER

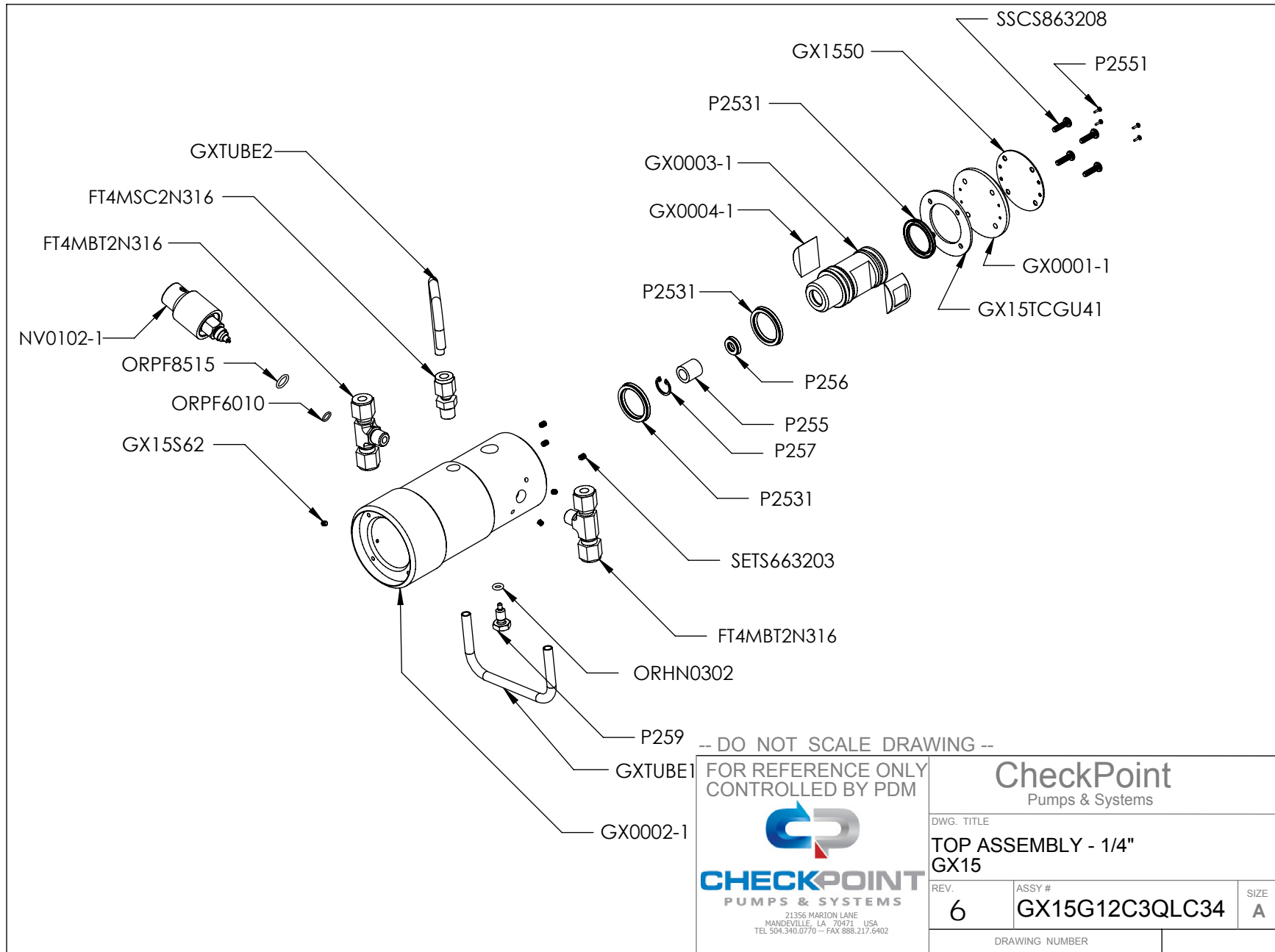

FOR REFERENCE ONLY  
CONTROLLED BY PDM





**CHECKPOINT**  
PUMPS & SYSTEMS  
21356 MARION LANE  
MANDERVILLE, LA 70471 USA  
TEL 504.340.0770 -- FAX 888.217.6402

<b>CheckPoint</b> Pumps & Systems		
DWG. TITLE <b>TOP ASSEMBLY - 1/4"</b> <b>GX15</b>		
REV. <b>6</b>	ASSY # <b>GX15G12C3QLC34</b>	SIZE <b>A</b>
DRAWING NUMBER		

BILL OF MATERIALS			
PART NUMBER	DESCRIPTION	QTY.	MATERIAL CODE
CDS04S6Q201	DISCHARGE CHECK	1	S6/HC/PF
CSS04IS6Q101	SUCTION CHECK	1	S6/HC/PF
FT4MBT2N316	TEE	2	S6
FT4MSC2N316	ADAPTER	1	S6
GX0001-1	TOP COVER	1	S6
GX0002-1	HOUSING	1	S6
GX0003-1	SPOOL	1	TC
GX0004-1	D SLIDE	2	TC
GX0005-5	PISTON	1	S6
GX0009-2	PLUNGER	1	S6/CE
GX0010-2	GLAND NUT	1	S6
GX0012-2	INJECTION HEAD	1	S6
GX1516	PISTON SEAL	1	UR
GX1550	S/N PLATE	1	S6
GX15S62	PLUG	3	S6
GX15TCGU41	TOP GASKET	1	UR
GXTUBE1	TOP TUBE	1	S6
GXTUBE2	BOTTOM TUBE	1	S6
NV0102-1	NEEDLE VALVE ASSY	1	N/A
ORHN0029	O-RING	1	HN
ORHN0302	O-RING	1	HN
ORPF6010	O-RING	1	PF
ORPF8515	O-RING	1	PF
P2522	ROD BUSHING	1	AC
P2527	BLEED POPPET	1	S6
P2529	BLEED SCREW	1	S6
P2531	U CUP SEAL	3	UR
P2545S7	CROSS PIN	1	S7
P255	SPOOL SPACER	1	TF
P2551	U-DRIVE SCREW	4	S6
P256	U CUP	4	UR
P257	SNAP RING	3	S6
P259	ALIGNMENT SCREW	1	S6
PRETPLHC107	RETAINER	1	HC
SETS663203	SET SCREW	3	S6
SPHC18001	SPRING	1	HC
SSCS863208	SCREW	4	S6
SSCSA63212	SCREW	4	S6
ZGX152505QLC	SEAL	1	TC/PF

-- DO NOT SCALE DRAWING --

FOR REFERENCE ONLY CONTROLLED BY PDM			
		DWG. TITLE <b>TOP ASSEMBLY - 1/4"</b> <b>GX15</b>	
REV.	ASSY #	SIZE	
6	GX15G12C3QLC34	A	
DRAWING NUMBER			

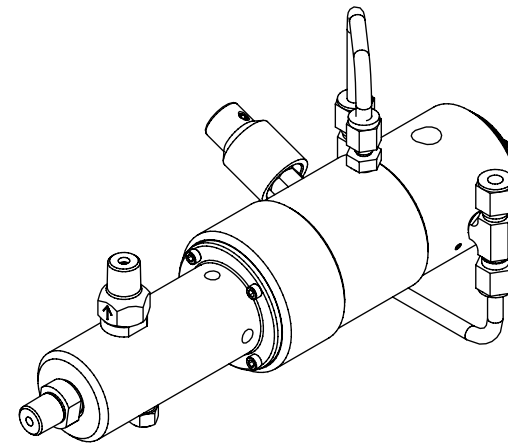
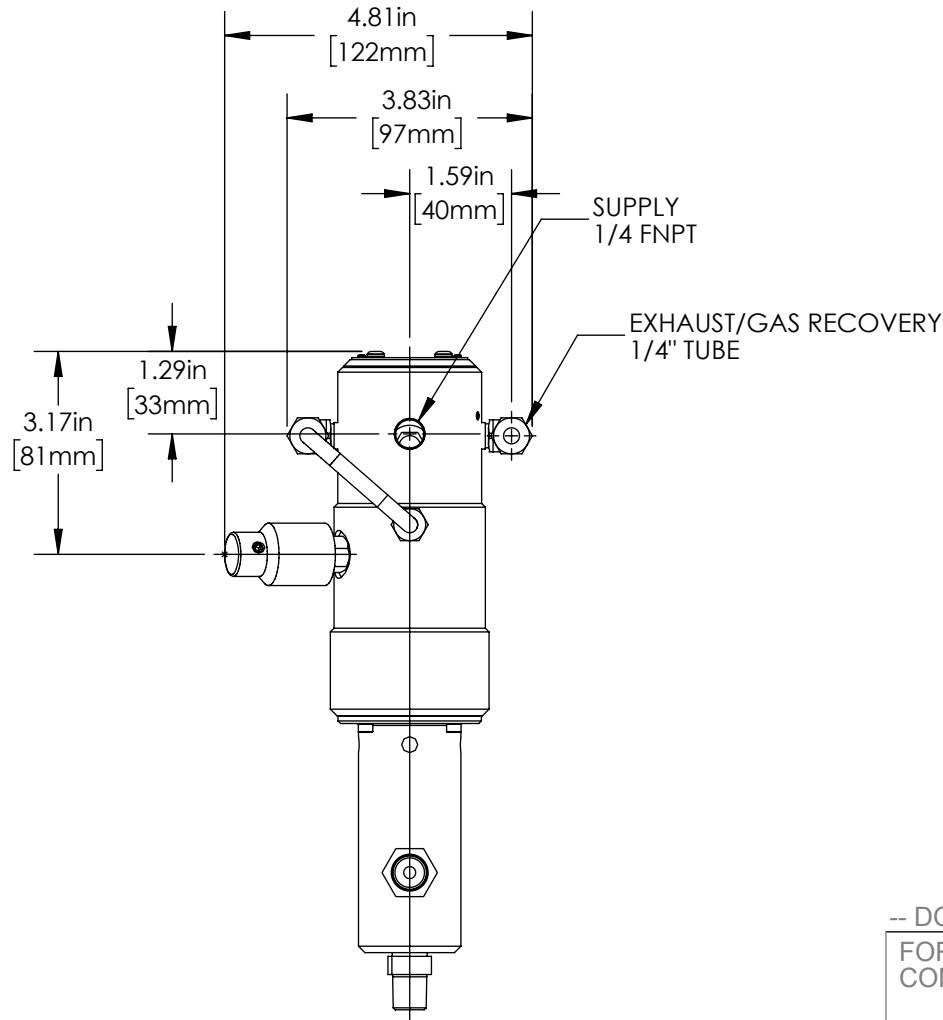

-- DO NOT SCALE DRAWING --

FOR REFERENCE ONLY  
CONTROLLED BY PDM



**CheckPoint**  
Pumps & Systems

DWG. TITLE

TOP ASSEMBLY - 1/4"  
GX15

REV.

6

ASSY #

GX15G12C3QLC34

SIZE

A

DRAWING NUMBER

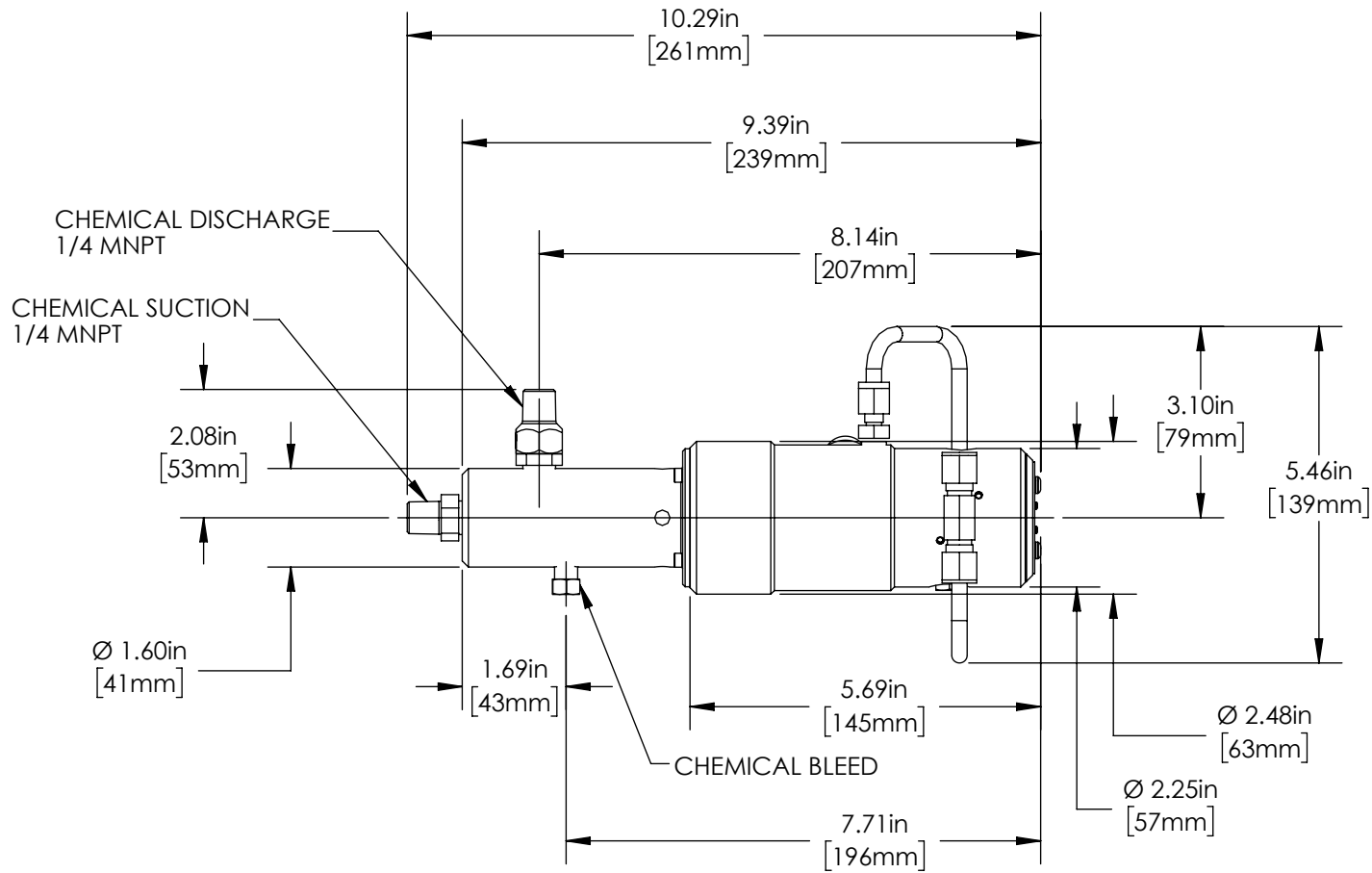

-- DO NOT SCALE DRAWING --

FOR REFERENCE ONLY  
CONTROLLED BY PDM



**CheckPoint**  
Pumps & Systems

DWG. TITLE

TOP ASSEMBLY - 1/4"  
GX15

REV.

6

ASSY #

GX15G12C3QLC34

SIZE

A

DRAWING NUMBER

MATERIAL CODES		
MATERIAL	CODE	Temperature (°C) Min/Max
304 Stainless Steel	S4	N/A
316 Stainless Steel	S6	N/A
17-4 PH Stainless Steel - HH 1150	S7	N/A
420 Stainless Steel	S0	N/A
5052 Aluminum	A5	N/A
6061 Aluminum	A6	N/A
Acetal	AC	-40/149
AFLAS®	AF	-
Buna-N®	BU	-40/121
Ceramic - Everwear™	CE	N/A
Ceramic - NBD200™	CN	N/A
DELFIN	DL	-40/149
Duplex 2205	D4	N/A
Super Duplex 2507	D5	N/A
Elgiloy®	EL	N/A
FKM	PF	-20/200
303 Stainless Steel	S3	N/A
FFKM	FK	-1/287
Hastelloy C276	HC	N/A
HNBR	HN	-52/149
Iron	FE	N/A
Low Carbon Steel	ST	N/A
Monel®	MO	N/A
PVC	PV	Max +140
PEEK	PK	-73/288
Teflon® - Bronze Filled	TB	-268/288
Teflon® - Carbon Filled	TC	-268/288
Teflon® - Glass Filled	TG	-268/288
Teflon® - Mineral Filled	TM	-268/288
Teflon® - Polyimide Filled	TP	-268/288
Teflon® - Virgin Filled	TF	-268/232
Titanium	TI	N/A
Ultra High Molecular Weight Polyethylene (UHMWPE)	UH	-268/288
Urethane	UR	-53/104
Viton®	VI	-23/232
XWL	XL	N/A