

# **Series FXA with Variator Control Technology Chemical Injection Pump Operating Manual**



**CheckPoint Headquarters**  
21356 Marion Lane  
Mandeville, Louisiana 70471  
United States of America  
+1 (504) 340-0770

**CheckPoint UK**  
C2/C3 Lombard Centre  
Kirkhill Place, Kirkhill Industrial Estate  
Dyce, Aberdeen AB21 0GU Scotland  
+44 (0)1224 775205

**CP Pumps & Systems FZE**  
P.O. Box 262131  
Jebel Ali Free Zone, FZS1 BL 06  
Dubai, U. A. E.  
+971 (4) 8806278

**CheckPoint Systems Pte Ltd**  
21 Toh Guan Road East  
#04-11 Room 1 Toh Guan Centre  
Singapore 608 609  
+65 6261 7687

## TABLE OF CONTENTS

<b>1. PUMP INSTALLATION</b>	<b>4</b>
1.1 Process Design & Setup .....	4
1.2 Connecting the Chemical Supply .....	7
1.3 Connecting the Power Supply .....	8
1.4 Motor Requirements .....	8
<b>2. PUMP OPERATION</b>	<b>8</b>
2.1 Primary / Backup Pump Selection .....	9
2.2 Bleeding/Priming the Injector Head.....	9
2.3 Adjusting the Pump Delivery Volume .....	10
2.4 Setting Delivery Volume – VFD or Variator .....	10
2.5 Packing Adjustment .....	13
2.6 Packing Replacement.....	14
<b>3. PUMP MAINTENANCE</b>	<b>16</b>
3.1 Lubrication .....	16
<b>4. TROUBLESHOOTING</b>	<b>17</b>
4.1 Pump runs, but chemical does not discharge at the correct rate .....	17
4.2 Pump Does Not Stroke .....	17
4.3 Pump is Excessively Noisy .....	18
4.4 Chemical Leakage from Packing.....	18
4.5 Other Problems.....	18

Congratulations! You have chosen the finest, most versatile electrically driven chemical injection pump made; designed to superior specifications for long life, reliable performance, and low maintenance. To ensure proper operation and to maximize the Series FXA's durability, please read and follow this manual. Failure to correctly install and maintain the pump is the primary cause of premature pump failure and voids the product warranty.

**NOTE:** This IOM applies to the CheckPoint FXA Electric Chemical Injector Pumps, part number FX0125-(FXA Code)-(Injector Assembly) for CheckPoint Series 1250 style heads, and FX0150-(FXA Code)-(Injector Assembly) for CheckPoint Series1500 style heads.

### **CheckPoint FXA Pump with Variator Flow Control**

This injector utilizes CheckPoint Variator technology, which replaces traditional mechanical stroke length adjustment mechanisms and electronic speed controls. The CheckPoint Variator is an intrinsically safe hydraulic speed control device that controls the pump flow rate by adjusting the motor output speed prior to the gearbox.

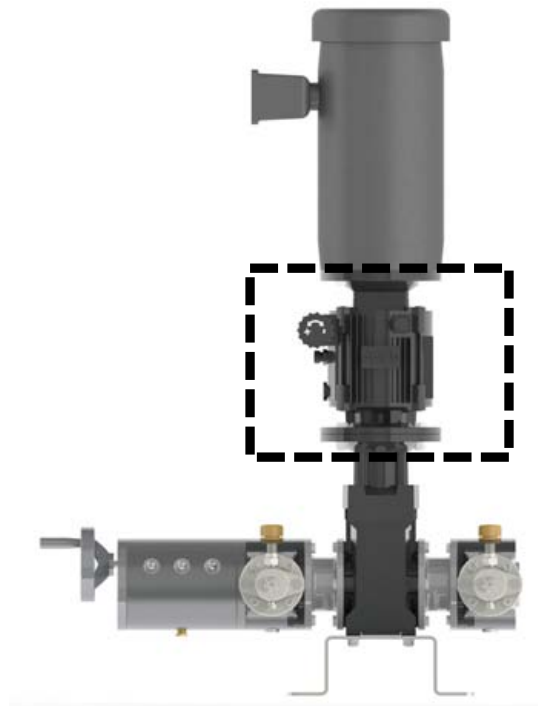

Advantages of CheckPoint Variator:

- API 674 and 675 compliant
- Intrinsically safe
- Extremely reliable
- Highly repeatable and accurate
- Replaces expensive, and often complicated VFD/VSD systems
- ATEX-certified
- Effective on plunger or diaphragm style pump heads

## **CheckPoint FXA Pump with Primary / Backup Pump Selection**

A primary / backup configuration contains two pumps, where at any one time only one of the pumps is physically engaged to the drive unit. A transfer mechanism positions the splined drive shaft in one of three positions; Primary, Backup or Neutral. Turning the crank moves the shaft through the unit connecting the gearbox output to one of two FXA drives. Three visual ports on the housing indicate the shaft position. The Transfer Mechanism can be installed on the left or right side. The pump closest to the mechanism is always considered the Primary pump.

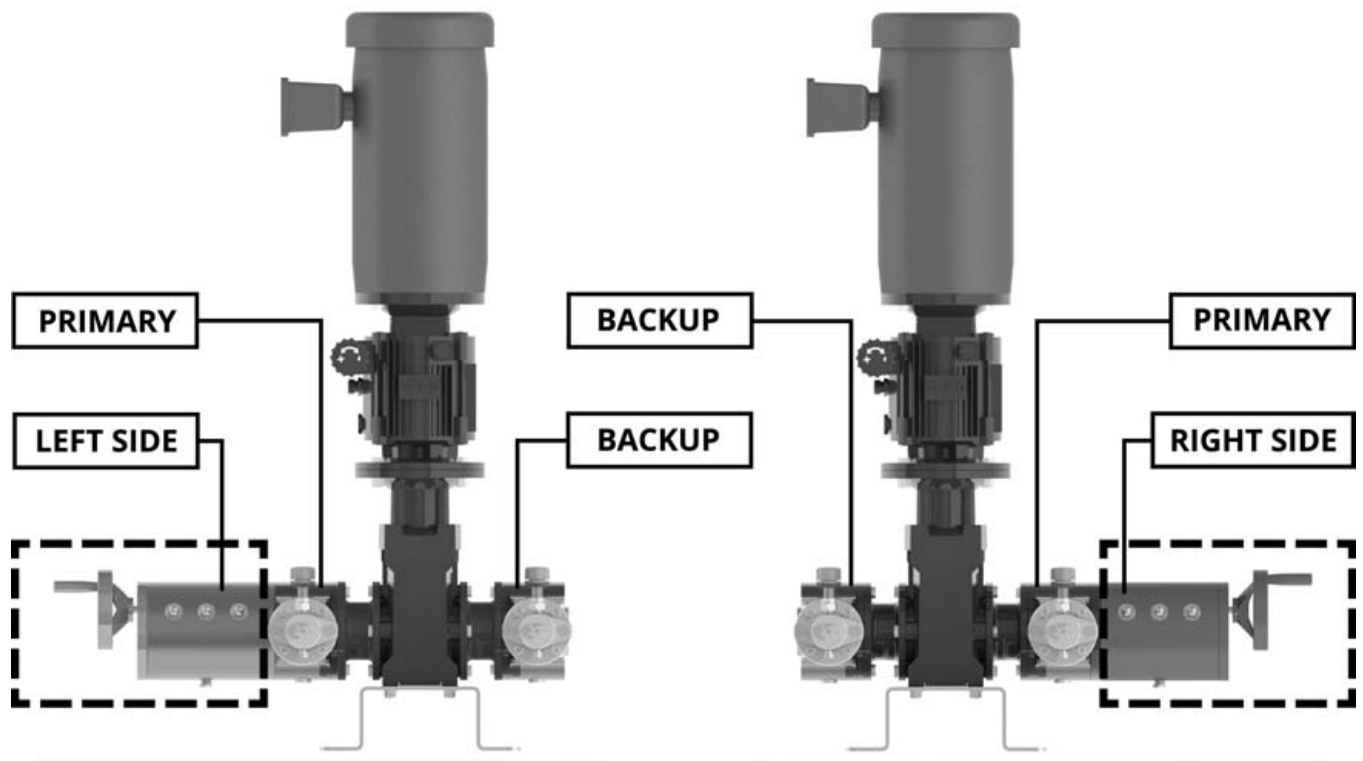

### **SPECIFICATIONS / BENEFITS**

- API 674 and 675 compliant
- Intrinsically safe
- Simple operation
- Allows servicing of one pump while other is in operation
- Allows secondary pump to be preset to desired flow rate
- Backup pump is not in motion (no seal wear while not pumping)

## **1. PUMP INSTALLATION**

### ***1.1 Process Design & Setup***

1.1.1 Before installation, please inspect the pump carefully. If the pump appears to have sustained damage in transit, call your CheckPoint Authorized Distributor or CheckPoint Customer Service directly at +1 (504) 340-0770 or [help@cppumps.com](mailto:help@cppumps.com) to confirm and report damage. If it is determined that damage occurred in transit, a carrier claim will be required.

**FIGURE 1: TYPICAL INSTALLATION SCHEMATIC**

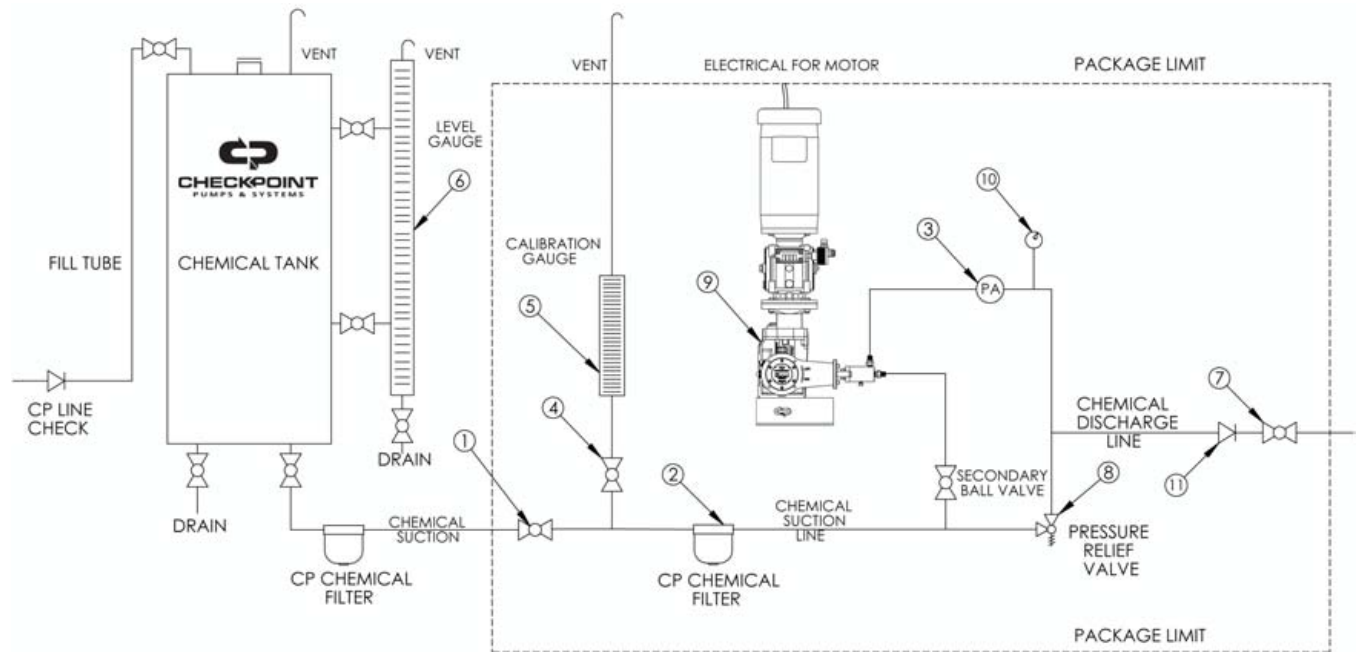

CheckPoint packages are available for the Series FXA pumps that contain all necessary components as indicated within the Package Limit Line. We can supply packages that contain ALL components, including the tank, mounted on a single skid with or without full leak containment.

- |                             |                                  |                               |                              |
|-----------------------------|----------------------------------|-------------------------------|------------------------------|
| 1. Suction line block valve | 4. Calibration Gauge Block Valve | 7. Discharge line block valve | 10. Discharge Pressure Gauge |
| 2. CP Chemical Filter*      | 5. CP Calibration Gauge*         | 8. PRV - Discharge Lline      | 11. Discharge Check Valve    |
| 3. Piston Accumulator*      | 6. Tank Gauge                    | 9. CP FXA Chemical Pump*      |                              |

\*CheckPoint OEM products.

All items in Figure 1 can be purchased directly from CheckPoint. Call today for our latest prices on pumps, gauges, packages and other components.

1.1.2 Referring to Figure 1, ensure that all necessary components are present in your injection system and are in good working order. All components shown above are recommended by CheckPoint to maximize pump life and productivity. In the event that you have questions regarding best practices, or if you need to purchase additional components, please contact CheckPoint for assistance. Representatives are on staff and are always available to answer your process questions. CheckPoint Engineers are also available to assist in system design. The CheckPoint Engineered Systems Department can be utilized for custom design and build options.

**NOTE:** The secondary chemical filter displayed in Figure 1 is optional under certain conditions but is always highly recommended.

**NOTE:** Chemical filters should be used as a final precaution to prevent contaminants from entering the pump—not as the primary method to clean chemical.

1.1.3 CheckPoint requires horizontal mounting for the Series FXA pump. Improper mounting will result in oil leakage from the breather vent. The FXA Base is provided to ensure proper orientation.

A suction-side calibration gauge or discharge flow meter is necessary to accurately set the pump flow rate. Many variables, including temperature and chemical viscosity, preclude the use of tables, graphs, and formulas to determine the rate of injection. Without a calibration gauge or flow meter, it cannot be determined if the pump is primed and functioning normally. For instructions on the proper use of a suction-side calibration gauge, please note: the pump's stroke rate is changed to achieve the desired flow rate when using a VFD or Variator.

1.1.4 The proper placement of a calibration gauge (Item 5) is shown in Figure 1. CheckPoint offers a complete range of accurate and durable calibration gauges and discharge-side flow meters.

**NOTE:** It is necessary to attach a vent tube to the top of all calibration gauges, chemical tanks, and tank level gauges. The height of the top of each vent tube should always be greater than the highest possible liquid level in the system. Proper vent tubes should have ways to prevent water entry, such as a 180 degree bend.

1.1.5 CheckPoint always recommends flooded suction; chemicals known to "gas off" require a flooded suction. However, the Series FXA does not require flooded suction or positive chemical pressure to prime. The Series FXA may be mounted above the chemical container. For a chemical with average viscosity, the pump will pull gas out of the chemical line and, depending on plunger size, can prime from up to twelve feet above the liquid level in the tank. This feature is dependent upon proper adherence to all points made in Paragraph 1.1.6 below.

1.1.6 ALL COMPONENTS AND PIPEWORK BETWEEN THE CHEMICAL TANK AND THE SUCTION CHECK VALVE OF THE PUMP MUST BE 100% BUBBLE-TIGHT AND FULLY COMPATIBLE WITH THE CHEMICAL AND WITH EACH OTHER. FAILURE TO ADHERE STRICTLY TO THIS DIRECTIVE WILL LEAD TO LOSS OF PRIME AND DAMAGE TO THE PLUNGER AND PLUNGER SEAL.

SPECIFICALLY:

1.1.7 All fittings and screw-on joints without Teflon™ tape or other equivalent sealant may allow air at atmospheric pressure to enter the suction tubing, even when no chemical leakage is visible.

1.1.7.1 Dissimilar metals in the suction side of the injection system may react with each other, creating gas bubbles that will be carried into the pump head. All suction components, tubing, pipe, fittings, and valves must be composed of similar or compatible materials. Please note that CheckPoint offers wetted parts composed of 316 SS, Hastelloy C, PVC, Titanium and Alloy 20.

1.1.8 The pump may be mounted to a skid or other surface in a number of ways; however, clamping around the outside of the pump can permanently affect the cylindricality of the injection head and/or FXA eccentric drive and may damage the protective coating, thereby voiding the product warranty. Proper mounting techniques increase accessibility during maintenance and troubleshooting. Your CheckPoint FXA purchase includes a standard pre-drilled base for proper pump mounting.

1.1.9 Always check to ensure that all process block valves (labeled Items 1, 4, and 7 in Figure 1) are closed prior to disconnecting or reinstalling any chemical injection pump. There should always be a block valve placed between the pump and the process flow, gas supply, and chemical supply. Conversely, while the pump is running, all such block valves should always be open.

1.1.10 The pump suction line should be sized appropriately based on the flow rate to avoid cavitation. A general rule of thumb is to size the suction line such that instantaneous flow velocity through the line does not exceed 2 feet per second at any point. Additional allowances may be needed for multiple pump

installations, extremely viscous chemicals, and chemicals with high vapor pressures; contact CheckPoint or your Authorized CheckPoint Distributor for design assistance.

1.1.11 TO AVOID OVER-PRESSURING CHEMICAL DISCHARGE LINES, CHECKPOINT REQUIRES PLACING A PROPERLY TESTED AND CALIBRATED PRESSURE RELIEF VALVE BETWEEN THE DISCHARGE PORT OF THE PUMP AND THE PROCESS FLOW. THE PRESSURE RELIEF VALVE DISCHARGE CAN BE RUN TO A TEE UPSTREAM OF THE PUMP'S CHEMICAL SUCTION CHECK VALVE OR REROUTED TO TANK. FAILING TO USE A PRV IS EXTREMELY DANGEROUS. EXCESSIVE PRESSURE MAY LEAD TO CATASTROPHIC FAILURE OF PROCESS EQUIPMENT OR BODILY HARM. CHECKPOINT IS NOT RESPONSIBLE FOR ANY DAMAGE CAUSED BY OVER-PRESSURIZED CHEMICAL. CheckPoint offers a range of pressure relief valves suitable for use with the FXA pump.

**CAUTION: When using a pressure relief valve, the chemical tank MUST BE properly vented to atmosphere. Venting helps avoid the possibility of tank over-pressurization if the pressure relief valve actuates.**

1.1.12 Depending on a variety of factors, pulsation dampeners or suction accumulators may be required in your installation. Consult with CheckPoint if you have any concerns about pulsation or NPSHa.

## 1.2 Connecting the Chemical Supply

1.2.1 Always clean suction lines and check chemical containers to ensure that they are free of all foreign matter, sand, sludge, or chemical buildup.

NOTE: Even new chemical tanks can contain debris which may cause system damage. Removing foreign debris from suction lines and chemical containers will substantially extend the life of the packing and other pump components.

NOTE: CheckPoint recommends using filtration to ensure a maximum particulate size of 140 microns. Multiple stages of filtration should be considered, depending upon the initial cleanliness level of the fluid media being pumped, to prevent cavitation and an increase in maintenance.

NOTE: If premature scoring of the pump plunger or early packing failure is observed during operation, a likely cause is abrasive particles carried into the pump through the suction plumbing. Use of a pre-suction in-line chemical filter such as the CheckPoint Series FSTS and/or a ceramic or Hastelloy™ plunger is recommended if symptoms continue. Call CheckPoint for appropriate filter element sizing criteria.

**CAUTION: Substantial scoring of the plunger can lead to premature packing failure and severe leakage of chemical into the surrounding environment.**

1.2.2 Connect the chemical suction line to the suction check valve on the pump head. The suction check valve is a male 1/4" NPT for the CheckPoint Series 1250 type headed injectors and male 1/2" or 3/4" NPT for the CheckPoint Series 1500 type headed injectors. Do not over-tighten NPT connections.

NOTE: To prevent leakage apply Teflon™ tape, or equivalent thread sealant, to the check valve threads prior to attachment.

NOTE: To operate properly, the check valve MUST remain directly attached to the chemical head. Never relocate the suction check valve away from the chemical head .

1.2.3 Connect your discharge line to the pump discharge check valve. Care must be taken not to over-tighten NPT connections.

Open the process block valve (shown as Item 7 in Figure 1), allowing the process pressure to reach the chemical head or in-line check valve. Observe and correct any leakage.

**CAUTION: The Series FXA pumps are capable of producing pressures in excess of 15KSI. If the discharge line is blocked for any reason, the pump can generate pressures in excess of the indicated rated pressures. A relief valve MUST be placed between the discharge port and the process flow to PREVENT CATASTROPHIC FAILURE OF PROCESS EQUIPMENT OR BODILY HARM. CHECKPOINT IS NOT RESPONSIBLE FOR ANY DAMAGE CAUSED BY OVER-PRESSURIZATION.**

NOTE: Always open the process block valve prior to operating the pump. Operating the pump with a closed block valve can generate enough pressure to rupture the discharge, damage process equipment and chemical head. Improper procedures may reduce the life of your CheckPoint pump.

### 1.3 Connecting the Power Supply

1.3.1 Special attention should be paid to motor type and location hazards prior to hookup. The electric motor must be connected in accordance with all local regulations and area classifications and should include overload protection.

1.3.2 It is recommended that the FXA installation is equipped with an easily accessible "emergency off" switch.

### 1.4 Motor Requirements

1.4.1 CheckPoint recommends a motor/gear reducer combination not exceeding 80 rpm at the FXA drive input shaft. The maximum rated rotational speed of the FXA input shaft is 120 rpm. NEVER EXCEED 120 RPM.

## 2. PUMP OPERATION

### 2.1 Primary / Backup Pump Selection

NOTE: (Refer to the Transfer Shaft Mechanism IOM for more details)

- Check the pump indicator to ensure that the proper pump is engaged.

NOTE: Only one pump can be engaged at a time.



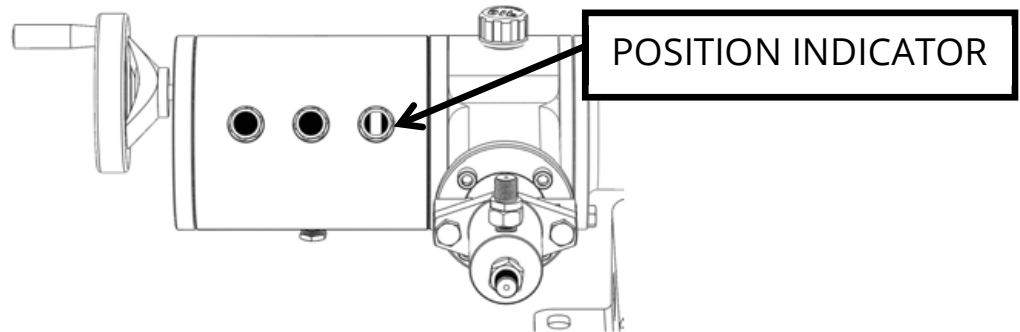

## 2.2 Bleeding/Priming the Injector Head

**NOTE:** Prior to initial pump operation, ensure that the suction check valve is connected to adequate chemical supply per Section 1.2.

2.2.1 The bleed screw on the Series 1500 injection head is fitted with a 1/8" NPT female connector to allow the user to tube chemical into the proper containment area or vessel.

2.2.2 Check to ensure that the packing nut is properly adjusted prior to starting the motor or bleeding air from the pump head. Read Section 2.5: Packing Adjustment before attempting to adjust or tighten the packing nut. It is important not to over-tighten the packing nut.

2.2.3 Open the chemical supply block valve labeled Item 1 in Figure 1.

2.2.4 Open the process block valve labeled Item 7 in Figure 1.

**NOTE:** OTHER THAN DURING BRIEF TESTING, NEVER OPERATE THE PUMP WITHOUT CHEMICAL SUPPLY FLOWING FREELY—DOING SO WILL CREATE UNDUE FRICTION AND HEAT, DECREASE THE LIFE OF THE PACKING, HASTEN CHEMICAL LEAKAGE, AND VOID THE PUMP WARRANTY.

2.2.5 Start the pump via Start/Stop switch.

2.2.6 If equipped with a Variator, set the Variator to maximum speed by turning the adjustment dial to the full counterclockwise (CCW) position.

**NOTE:** If the pump is not new, it is possible for dried or solidified chemical to be present in the bleed and check valve assemblies. If your pump does not bleed when following the directions above, try cleaning these items in solvent and/or replacing them.

2.2.7 Open the bleed screw 1½ to 2 turns. The pump will begin to pull air and chemical through the chemical supply plumbing, into the head, and out of the bleed port. Leave the valve open until a solid stream of chemical pumps out of the bleed port each stroke.

**NOTE:** If the pump is not new, it is possible for dried or solidified chemical to be present in the bleed and check valve assemblies. If your pump does not bleed when following the directions above, try cleaning these items in solvent and/or replacing them.

2.2.8 Close the bleed screw until chemical flow stops. Torque the bleed screw to 10 in-lb.

**NOTE:** DO NOT OVER-TIGHTEN THE BLEED SCREW; ONLY TIGHTEN UNTIL CHEMICAL STOPS FLOWING. APPLYING EXCESS TORQUE TO THE BLEED VALVE MAY IMPAIR FUTURE VALVE OPERATION.

NOTE: Occasionally, soon after closing the bleed assembly, you may observe leakage past the packing. If so, this is usually due to a loose packing nut. Turn off pump, relieve pressure and adjust the packing nut per the instructions in Section 2.5 "Packing Adjustment".

### 2.3 Adjusting the Pump Delivery Volume

NOTE: The stroke length of the Series FXA pump remains constant at all times.

2.3.1 Pump Delivery Volume is set by adjusting the input speed to the FXA:

- Variator - Vary the RPMs of the power drive mechanism by turning the Variator speed control knob.
- Adjusting the motor RPM during operation will not damage the Series FXA pump. The variator can be adjusted when stopped or while running. Accurate setting of the Variator requires it be in motion.

NOTE: (Refer to the Variator IOM for more details)



### 2.4 Setting Delivery Volume – VFD or Variator

NOTE: The pump's stroke rate is changed to achieve the desired flow rate when using a VFD or Variator.

#### 2.4.1 Determine Delivery Volume Using a Calibration Gauge

The following directions are for measuring the delivery volume using a calibration gauge. There is a variety of calibration gauges available, including a complete line of appropriately-sized CheckPoint gauges for every CheckPoint pump. It is important to use a calibration gauge or a discharge-side flow meter to ensure proper pump function and chemical flow rate.

2.4.1.1 Most calibration gauges are designed to read properly using a one-minute test. However, if the liquid level drops too fast to allow for a full minute test, shorter periods are acceptable. Size the gauge so that at least a 15 second test can be achieved. Tests shorter than 15 seconds will result in a loss of accuracy.

Proper gauge placement and plumbing is important. Please refer to Figure 1 (Item 5) for appropriate valving, placement, and reference numbers as used in this section. The calibration gauge is labeled as Item 5.

2.4.1.2 With the pump either running or stopped, open the Gauge Fill Valve (Item 4 in Figure 1). The gauge should begin to fill. Continue filling until the chemical level is at or near the top markings on the gauge.

2.4.1.3 Ensure that the CheckPoint pump is running. Take note of the level of chemical in the gauge using the appropriate scale for the volume units you want to measure. Usually the gauge will show liters on one scale and quarts or gallons on the other. It is best to write down the number so that you can accurately calculate the flow.

2.4.1.4 Close the Suction Line Block Valve (Item 1 in Figure 1). The pump's chemical is now supplied directly from the calibration gauge.

2.4.1.5 The level in the gauge should begin to fall. (If it does not, or if the level seems to go down and then back up with each stroke, refer to Section 5, Troubleshooting. Stop timing when the liquid level in the gauge approaches the bottom of the gauge, or when one minute has expired, whichever comes first. Note the ending level on the gauge, and reopen the Chemical Supply Valve.

2.4.1.6 Write down the amount of time in seconds and the final gauge reading, then close the Gauge Fill Valve.

NOTE: In cases where the chemical flow rate is extremely low, you may need to time for longer than one minute to allow an adequate amount of chemical to move out of the gauge.

NOTE: Failure to reopen the Chemical Supply Valve will result in the pump quickly depleting the remaining chemical in the gauge and running on air, necessitating pump re-priming.

2.4.1.7 The pumping volume (in the units specified on the gauge scale) will be given by the following equation:

$$\text{PUMPING VOLUME} = \frac{[\text{END READING}] - [\text{BEGINNING READING}]}{[\text{DURATION OF READING IN SECONDS}]} \times 60$$

NOTE: To ensure accurate stroke rate measurement, allow sufficient measurement duration. Where possible, allow at least 15 seconds of gauge drawdown.

#### 2.4.2 Calculation of Stroke Rate

To determine if a particular plunger or pump size will output a required volume, calculate the required stroke rate using the following procedure. You will need the volume factor from Figure 2 and the discharge compensated flow rate from the chart in Figure 5 below.

NOTE: This procedure assumes full strokes and should not be used as the sole method of setting the pump's speed in the field. Without checking the pump's output with a calibration gauge, you cannot be assured that the pump is delivering the correct liquid flow rate. For example, if the suction check valve is stuck due to trash or thickened chemical, chemical would not be injected even if the stroke rate has been properly set.

2.4.2.1 Using your desired chemical flow rate, calculate an Unrated Stroke Rate (USR). UNRATED STROKE RATE (USR) (STROKES/MIN) = FLOWRATE (QT/DAY) X VOLUME FACTOR. Figure 2 contains volume factor using the Series 1250. Figure 3 contains volume factor using the Series 1500. Figure 4 contains basic conversions to assist you. Figure 5 is the volume de-rating percentage vs. discharge pressure.

**FIGURE 2: VOLUME FACTOR TABLE, SERIES FXA 1250 TYPE**

PLUNGER DIAMETER (IN)	VOLUME FACTOR
1/8"	3.477
3/16"	1.545
1/4"	0.869
3/8"	0.386
1/2"	0.217

**FIGURE 3: VOLUME FACTOR TABLE, SERIES FXA 1500 TYPE**

PLUNGER DIAMETER (IN)	VOLUME FACTOR
3/8"	1.452
1/2"	0.817
3/4"	0.363
1"	0.204
1 1/2"	0.091

**FIGURE 4: GENERAL CONVERSION TABLE**

TO CONVERT:	TO:	MULTIPLY BY:
GALLONS	QUARTS	4.00
LITERS	QUARTS	1.058
CUBIC INCHES	QUARTS	0.0173
MINUTES	DAYS	0.000694

**FIGURE 5: VOLUME DE-RATING PERCENTAGE VS DISCHARGE PRESSURE**

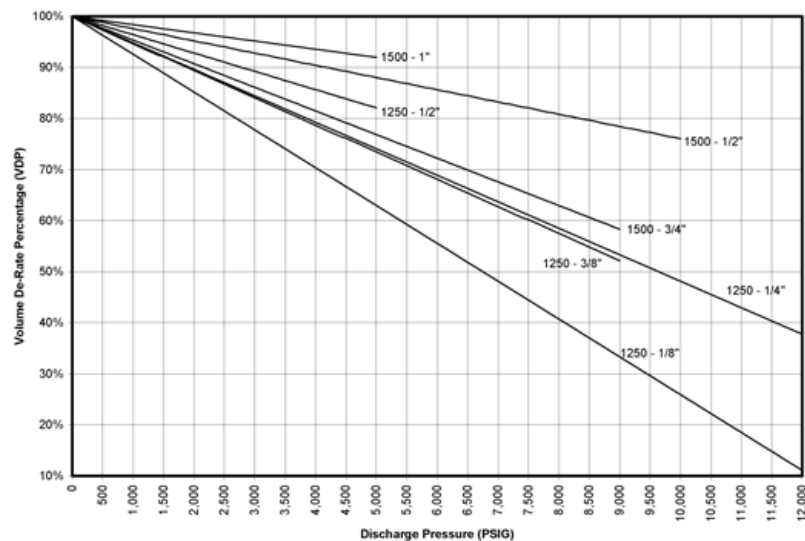

2.4.2.2 Volume per stroke decreases as the discharge pressure rises. It is necessary to apply a Volume De-Rating Percentage (VDP) to the Unrated Stroke Rate (USR). The VDP is based on the expected discharge pressure the pump will experience. Use the VDP Graph (Figure 5) to find the VDP, taking care to use the curve for your specific plunger diameter:

2.4.2.3 Use the resulting VDP to calculate the Target Stroke Rate as follows:

$$\text{TARGET STROKE RATE} = \frac{[\text{USR}]}{[\text{VDP}]}$$

2.4.3 Finally, ensure that the Target Stroke Rate does not exceed the maximum recommended stroke rate. If the Target Stroke Rate exceeds the maximum recommended stroke rate for the type of service you intend, it will be necessary to use a larger plunger size.

2.4.4 Assuming your pump is correctly sized; simply adjust the Variator until the Target Stroke Rate is achieved. Check the delivery volume per Section 2.4.1 "Determine Delivery Volume Using a Calibration Gauge". Readjust the stroke rate and check delivery volume as required to achieve target rate.

## 2.5 Packing Adjustment

2.5.1 There are a couple of key indicators that packing adjustment is necessary:

- 1) Leakage is observed around the packing nut
- 2) Leakage is visible from the weep hole drilled through the packing nut.

In most cases, if there is no leakage, no adjustment is necessary.

2.5.2 Use a CheckPoint T55-101 packing adjuster, which is specifically designed for this purpose. If the packing tool is not available, you may order one at no charge directly from CheckPoint. In an emergency or if time is short, a 6" length of 1/4" OD tubing or metal rod may be used.

2.5.3 If your pump is already in service, adjust the packing while pump is running.

2.5.4 To tighten the packing, insert the tool into one of the six shallow radial holes in the packing nut (Packing Nut is TYP. as in Figure 6), and tighten the nut clockwise (when looking at the pump from above). Snug the nut until light pressure with one finger on the packing nut tool no longer moves the packing nut.

2.5.5 From this point, TIGHTEN THE NUT 1/8 TURN ONLY as follows:

2.5.6 If adjusting the packing while pump is operating, pause after each 1/8 turn to determine if the leakage has stopped, allowing for enough time to ensure that previous leakage has already drained from the nut weep holes and threads. If the pump is still leaking, turn packing nut an additional 1/8 turn and check again. Continue turning the nut 1/8 turn at a time as often as necessary to stop the leakage. If the leakage cannot be stopped, or if excessive force is required to stop leakage, it is time to replace the packing.

2.5.6.1 If adjusting the packing prior to new installation or when not currently running, tighten the nut 1/8 turn from the finger-tight position.

NOTE: If the packing is being adjusted while the pump is running, the pump will typically not stall no matter how much the packing nut is tightened. Therefore, care must be taken not to apply too much pressure during adjustment. Overtightening the packing nut can dramatically reduce the packing's working life.
---

## 2.6 Packing Replacement

Follow the steps below to change the packing.

NOTE: The 3/16", 1/4", and 3/8" plunger sizes on the Series FXA 1250 type head and the 1/2" and 3/4" plunger sizes on the Series FXA 1500 type head require a metal adapter sleeve in the packing gland. When removing the packing, this sleeve should also be removed and cleaned. It is important to remember to re-install the sleeve.

NOTE: 1250 Series - The 3/16" plunger size requires an O-ring, a backup ring, and a snap ring.

NOTE: 1500 Series - The 1/2" and 3/4" plunger sizes require a metal adapter sleeve with an O-ring and backup ring.

2.6.1.1 Shut off power to the pump.

2.6.1.2 Close the block valves on the chemical supply and discharge, and bleed off residual pressure.

2.6.1.3 Disconnect the chemical supply from the pump at the suction check valve, and disconnect the discharge line from the discharge check.

2.6.1.4 Remove the chemical head by removing the two head bolts and then separating the head component from the body of the pump.

2.6.1.5 Unscrew and remove the packing nut using 1/4" tubing or a packing nut tool. A packing nut tool is available at no charge from CheckPoint. For all sizes other than the Series 1250 - 1/8" and 3/16" and the Series 1500 - 1/2" and 3/4" proceed to step 2.6.1.7.

2.6.1.6 Using the suction check hole for access, push out the packing and sleeve with a punch or screwdriver.

2.6.1.7 Remove the packing from the sleeve, along with the O-ring and backup ring on the small outside diameter of the sleeve. Clean the sleeve and lightly coat with lithium based grease, then install the new O-ring and backup ring supplied with your new packing. If you cannot locate these parts, please contact CheckPoint for replacements. The Series 1250 - 1/8" and 3/16" and the Series 1500 - 1/2" and 3/4" pumps may leak chemical without replacing these components whenever you replace the packing.

2.6.1.8 Replace the metal sleeve (if so equipped). Take care not to pinch the O-ring or backup ring between the sleeve and the injection head.

2.6.1.9 Prior to installation, examine the new packing set closely and ensure that it is oriented properly according to Figure 6. Your packing will be similar to the cross sectional view shown.

**FIGURE 6: TYPICAL PACKING INSTALLATION**

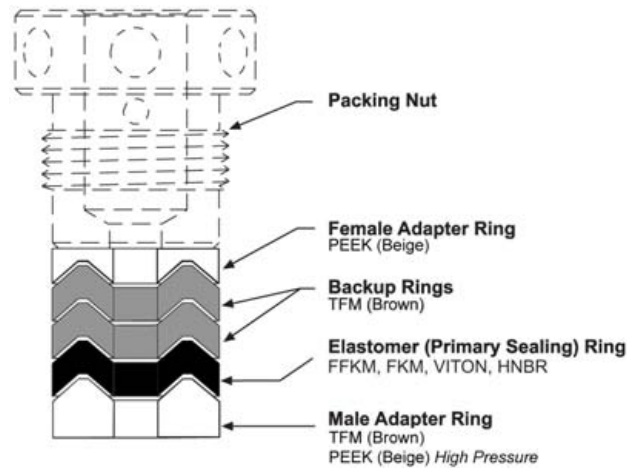

**NOTE:** When replacing adjustable packing, always install the packing rings exactly as they are shipped. Rearranging the order of the V-rings in an adjustable packing set will reduce the life of the elastomer ring in the packing set.

2.6.2 Grease the packing rings on their outside diameters lightly and install them, one ring at a time. It is important to adhere to the ring order and orientation as shown in the diagram.

**NOTE:** On the 3/16" 1250 and the 1/2" and 3/4" 1500 type head, the packing fits inside the sleeve rather than directly into the packing gland.

2.6.3 On the 1/8" and 3/16" plunger model, replace the internal snap ring to retain the sleeve.

2.6.4 Grease the packing nut threads and replace the nut loosely by hand.

2.6.5 Grease the plunger rod protruding from the pump drive.

2.6.6 Carefully insert the plunger into the packing without damaging or bending it, and replace the chemical head onto the main body of the pump.

2.6.7 Grease the threads on the two head bolts, then insert and hand-tighten them.

2.6.8 Tighten the packing nut to the point where light pressure with one finger on the packing nut adjuster will no longer move the packing nut.

2.6.9 Fully tighten down the head bolts. Failure to adhere to this procedure can lead to a misaligned head and leaking packing.

2.6.10 Reattach all process lines to the chemical head, and open all isolation valves leading to the pump chemical supply and discharge.

2.6.11 Adjust the packing nut per the directions in Section 2.5.

### 3. PUMP MAINTENANCE

The CheckPoint Series FXA is designed to provide trouble-free operation for many years with little adjustment, lubrication, or other routine maintenance. However, like any other device, proper maintenance can extend the life of the product. This can include periodic cleaning of the chemical inlets and lubrication.

#### 3.1 Lubrication

The CheckPoint Series FXA reciprocator drive contains internal rotating parts that require constant lubrication. The housing for the drive serves as an oil reservoir and requires the oil level to be above the centerline of the plunger adapter. To facilitate the monitoring and accurate level control of the lubricating fluid, two sight plugs are installed on the housing. Fill the FXA with oil until the “normal/low” sight is covered but no oil is present in the “high” sight. If the oil level drops below the “normal/low” sight, suspend operation until the level can be resored. The proper oil level is indicated in the figure below.

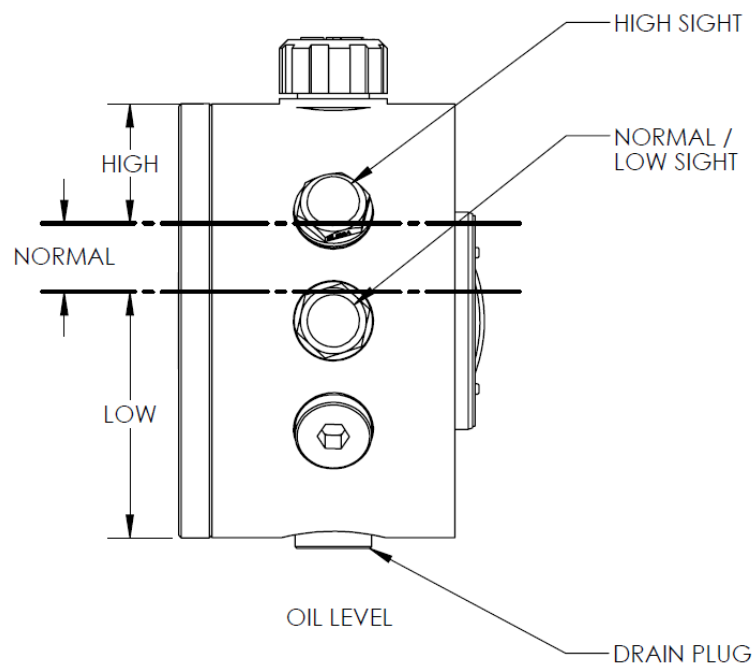

**Startup** The Series FXA pump is delivered with an empty reservoir. Prior to startup, fill FXA drive housing using 7 ounces (207mL) of SAE rated 5W-30 motor oil. CheckPoint recommends using Fully Synthetic oil for longer life. Before filling with oil, ensure that the drain plug in the bottom of housing is installed. Remove the top breather vent in the housing. Use a funnel to pour oil into the housing. Replace the top breather vent after filling with oil. Take care not to over-tighten the connections.

3.1.1 **Periodic Inspection** For proper operation, oil must be above the centerline of the pump. Remove the top breather vent, and inspect the fluid level monthly or as conditions require. Add oil as required to maintain proper levels.

3.1.2 **Oil Change** CheckPoint recommends changing the drive oil every 2,000 hours.



3.1.3 **Cold Weather** Operating the FXA in climates where temperatures fall below 20°F may require thinner oil. CheckPoint recommends using a Fully Synthetic 0W-20. For extremely low temperatures, external methods to add heat prior to startup are recommended. Once in operation, the FXA will produce sufficient heat to maintain oil fluidity.

## 4. TROUBLESHOOTING

### 4.1 Pump runs, but chemical does not discharge at the correct rate

4.1.1 **Suction check valve may be clogged with debris** To flush, allow the pump to cycle at maximum rate for at least 60 seconds. If no improvement is noted, remove the suction check valve from body of pump. Blow the check out with air or water pressure. If the first attempts are unsuccessful, a check rebuild could be necessary.

NOTE: CheckPoint FailSafe™ check valves do not need replacement when they do not check properly. A simple rebuild kit is available to replace the O-rings, which corrects all but the most severe check problems. Corrosion of the valve seat, retainer, or poppet indicates an incorrect check valve material. Please contact CheckPoint to request chemical compatibility information.

NOTE: Always replace Teflon™ tape or other appropriate thread sealant on check valve threads during reinstallation to avoid chemical leakage or the introduction of air to the chemical head.

4.1.2 **Pump may have lost prime and become “air locked”** Check to ensure that there are no leaks in any process lines, particularly upstream of the pump, within the chemical suction lines. If air is introduced through the suction side, the pump may lose prime. Read Section 1.1.6 and its subparagraphs carefully for details. A common source of air in the supply is the block valve ahead of the suction check. Check this valve to make sure that the stem packing is tight and that the materials of construction are compatible with the chemical being pumped. Also, check that the pump's packing is not leaking. Finally, with pumps supplying chemical into gas lines, it is possible that the discharge port may be leaking. A leaky discharge port may allow gas under pressure to “back into” the chemical head.

4.1.3 **Check valves may have been re-located away from the chemical head of the pump** The checks must stay directly attached to the head in order to facilitate chemical movement.

4.1.4 **Chemical may be obstructed from entering the pump** Pumping upstream of the chemical head may allow a blockage which prevents chemical from getting to the suction check valve. A common example is an in-line chemical filter becoming clogged with debris. Solution - clean out suction plumbing and clean or replace the chemical filter.

4.1.5 Chemical supply line size or configuration may cause NPSHa to drop below NPSHr.

4.1.6 **Calibration gauge may be reading incorrectly due to clogged air vent** If the calibration gauge is not reading correctly, it may appear chemical is not getting into the process. Check for an obstruction in the gauge or in the air vent atop the gauge.

### 4.2 Pump Does Not Stroke

4.2.1 **Check power to motor** Ensure motor has required power supplied and is turned on.

4.2.2 **Motor power is too low** Ensure proper motor sizing for the particular application. Contact your Authorized CheckPoint Distributor for sizing assistance.

4.2.3 **Plunger adapter pin is sheared** Inspect the connection between the plunger and plunger adapter. If the plunger is disconnected from the plunger adapter, contact CheckPoint directly or your Authorized CheckPoint Distributor.

4.2.4 **Drive cam follower is damaged** Contact CheckPoint directly or your Authorized CheckPoint Distributor.

4.2.5 **Shaft or shaft keyway is damaged** Contact CheckPoint directly or your Authorized CheckPoint Distributor.

#### 4.3 Pump is Excessively Noisy

4.3.1 **Drive components may be worn** Motor or gear reducer may be worn. Contact your drive component manufacturer.

4.3.2 **FXA shaft or follower may be worn** Clearances between rotating components may have increased due to wear.

NOTE: When troubleshooting for excessive noise, care must be exercised as noise may appear to come from sources other than the worn component.
--

#### 4.4 Chemical Leakage from Packing

4.4.1 **Packing may be worn** Prior to replacing the packing, it is important to determine if wear is premature. Common causes of prematurely worn packing are:

4.4.1.1 **Chemical may be attacking packing elastomer material** Remove the packing from the packing gland; if the packing has been subject to chemical attack, it will appear swollen or badly damaged. Contact CheckPoint or your Authorized CheckPoint Distributor. If the chemical has recently been changed or if the pump has just been placed in service, there is a good chance that new packing materials are required.

4.4.1.2 **Chemical may be attacking plunger material** The plunger will be severely worn, pitted, or corroded when inspected.

4.4.1.3 **Chemical may have abrasives suspended in it** The plunger will appear scored, and the packing will appear severely worn. CheckPoint offers high-performance chemical filters appropriate for Series FXA applications.

#### 4.5 Other Problems

If you are experiencing an operating problem not listed above, or if none of the above troubleshooting actions solve your operating problem, please contact your Authorized CheckPoint Distributor or contact CheckPoint directly at +1 (504) 340-0770 or help@cppumps.com. We will work to assist you in determining the appropriate next steps. Once CheckPoint has had the opportunity to help you troubleshoot your problem, please keep in mind the following regarding repairs:

4.5.1 **CheckPoint offers exchange programs to keep you in service** We will ship you a rebuilt pump, which you will be able to install prior to sending us your existing pump. Upon receipt of your pump, we will tear it down, rebuild, and report to you our findings. We offer a fixed-price exchange plan, an actual-cost plan, and a consigned exchange plan. Please contact CheckPoint to learn more about our unique exchange services.

4.5.2 **Nothing beats factory-direct repairs** Although the Series FXA pump has been designed to be easy to operate and repair, the best way to ensure continued reliable service is to have your pump repaired by the factory. OEM repair services ensure CheckPoint quality and reliability.



4.5.3 **Remember that after you repair your CheckPoint pump, it should perform like new** If your pump is anything less than exceptional, call us to determine what can be done to restore the pump to “like-new” performance.

4.5.4 **Training sessions are available** CheckPoint strives to maintain excellence in all that we do & we are happy to share. If you would like to train your employees on CheckPoint Pumps & Systems, please contact us to discuss training options.